

7500iL SMOKE METER



The Data Collection Unit (DCU) is the heart of the Model 7500iL system. This small, portable, lead acid battery powered unit collects information from up to three sensors.

- PC based opacity meter
- Reads in opacity or density
- Monitors RPM/ Oil Temperature
- Contains a weather station
- Easy to use management functions allow for data collection and downloads
- Available in 220V

Wager offers a variety of in-line opacity meters for monitoring diesel emissions. Stack pieces and custom lens sets are available for light duty, medium duty and heavy duty application. Wager models 6500il, 7500il and the Stack Check may all be configured as in-line systems

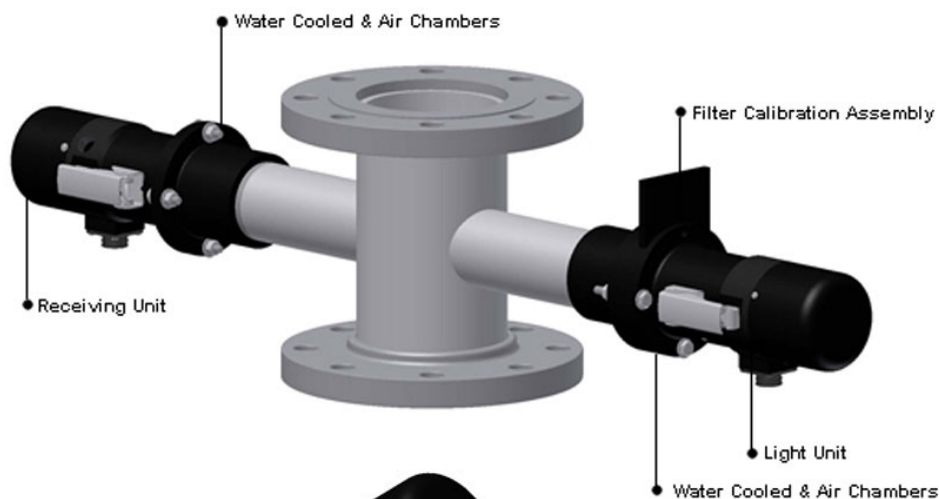

Heavy Duty Lens Set

Model 7500il Smoke Meter Complete

Includes: (Part No. 7500C-il)

- Control Unit
- Power Supply Transformer
- 50 Ft. Heavy Duty Shielded Cable
- PC Interface Cable
- Software interface
- Calibration Filter Assembly
- Receiving Unit - (Water Cooled Optional)
- Light Unit - (Water Cooled Optional)
- Laptop Assembly
- Stack piece