

2050-100i MARINE ODOR CONTROL SEWER VALVE

The 2050-100i marine odor control vent valve is designed to allow for ventilation of black and grey water tanks, while providing necessary odor control at the tank's location.

The 2050-100i is constructed from aluminum, and is epoxy coated to protect the unit from corrosion in the harsh sea environment. It contains (2) fifty pound canisters of odor scrubbing media, and 2 check valves that allow up to 500 CFM of fresh air to enter directly into the tank during pumping sequences. Each unit has a louvered cover to allow for maximum air flow of deodorized air. Covers have stainless steel lockable latches to prevent tampering.

The 2050-100i mounts vertically on the deck of the ship. It is available with a 4" ANSI 150 flange. Metric flanges are available upon request. Wager's media is engineered in pellet form to allow for adequate airflow thru the media bed, and is highly effective in removing H₂S gas. Pellets are non-toxic, and landfill disposable. Wager media has a 99.5% efficiency rate in the removal of sewage odors.

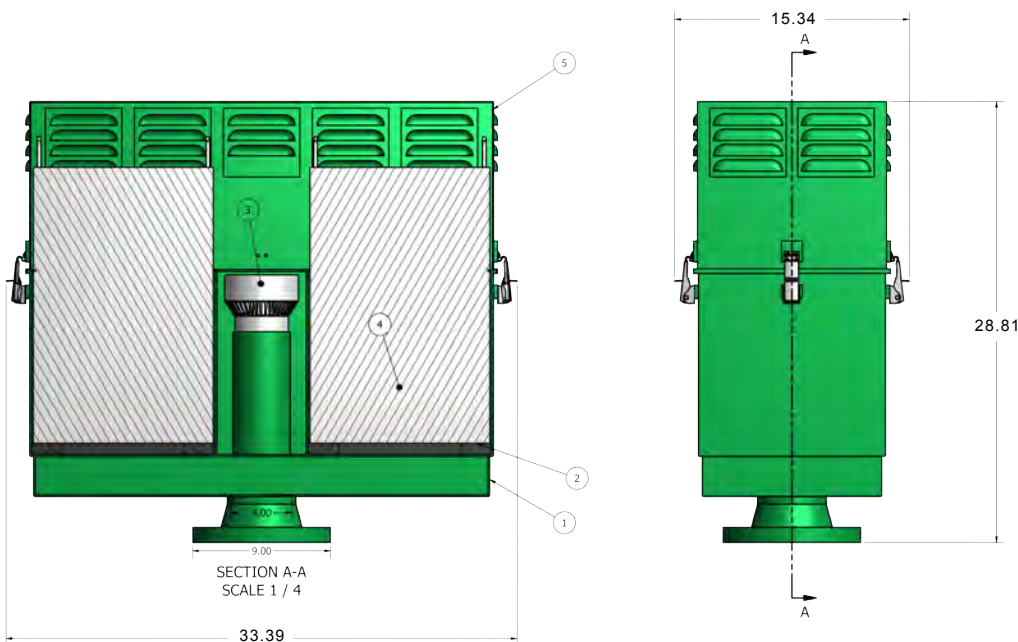

2050-100i SPECIFICATIONS

LOCATIONS USED

- PUMP STATIONS
- LIFT STATIONS
- WET WELLS
- FORCED MAINS

BODY

- ALUMINUM
- EPOXY COATED GRASS GREEN
- LOCKABLE LATCHES
- 4" OR 6" FLANGED OR THREADED CONNECTION

MEDIA

- 100 LBS OF ODOR CONTROLLING MEDIA
- 2- 50 LBS DROP IN REPLACEABLE CONTAINERS
- MEDIA AND BINS LANDFILL DISPOSABLE
- COMPLIMENTARY LAB ANALYSIS OF MEDIA

INTAKE VALVES

- 4 INTAKE VALVES
- UP TO 1000 CFM FRESH AIR INTAKE



WAGER
COMPANY

WWW.WAGERUSA.COM
Toll Free USA: 800-562-7024