

Society of Automotive Engineers (SAE)
J1667 Recommended Practice

Snap Acceleration Smoke Test Procedure for
Heavy-Duty Powered Vehicles

© 1996 Society of Automotive Engineers, Inc.

In order for the California Air Resources Board (ARB) to comply with SAE copyright, the customer is only allowed to view and **print one (1) copy** of this document. If additional copies are needed for your use, they may be obtained at a discount by contacting the SAE Copyright Administrator at SAE, phone: 724.772.4028.

Submitted for recognition as an American National Standard

**SNAP-ACCELERATION SMOKE TEST PROCEDURE FOR
HEAVY-DUTY DIESEL POWERED VEHICLES**

Foreword—This Document has not changed other than to put it into the new SAE Technical Standards Board Format.

TABLE OF CONTENTS

1.	Scope	2
1.1	Purpose	2
2.	References	2
2.1	Applicable Publications.....	2
2.2	Related Publications.....	2
3.	Definitions.....	3
4.	Special Notes and Conventions	4
5.	Snap-Acceleration Test.....	4
5.1	Vehicle Preparation and Safety Check	4
5.2	Test Preparation and Equipment Set-up.....	5
5.3	Driver Familiarization and Vehicle Preconditioning.....	6
5.4	Execution of the Snap-Acceleration Test	7
5.5	Calculation and Reporting of Final Test Results.....	9
6.	Test Instrumentation Specifications	9
6.1	General Requirements for the Smoke Measurement Equipment	9
6.2	Specific Requirements for the Smoke Measurement Equipment	9
6.3	Instrument Response Time Requirements	9
6.4	Smokemeter Light Source and Detector	10
6.5	Specifications for Auxiliary Test Equipment.....	11
7.	Smokemeter Maintenance and Calibration	11
	Appendix A Second-Order Filter Algorithm Used to Calculate a Maximum 0.500 s Average Smoke Value.....	12
	Appendix B Corrections for Ambient Test Conditions	21
	Appendix C Application of Corrections to Measured Smoke Values.....	31
	Appendix D Exhaust Systems and Special Applications.....	36

SAE Technical Standards Board Rules provide that: "This report is published by SAE to advance the state of technical and engineering sciences. The use of this report is entirely voluntary, and its applicability and suitability for any particular use, including any patent infringement arising therefrom, is the sole responsibility of the user."

SAE reviews each technical report at least every five years at which time it may be reaffirmed, revised, or cancelled. SAE invites your written comments and suggestions.

**QUESTIONS REGARDING THIS DOCUMENT: (724) 772-8512 FAX: (724) 776-0243
TO PLACE A DOCUMENT ORDER; (724) 776-4970 FAX: (724) 776-0790
SAE WEB ADDRESS <http://www.sae.org>**

SAE J1667 Issued FEB96

1. **Scope**—This SAE Recommended Practice applies to vehicle exhaust smoke measurements made using the Snap-Acceleration test procedure. Because this is a non-moving vehicle test, this test can be conducted along the roadside, in a truck depot, a vehicle repair facility, or other test facilities. The test is intended to be used on heavy-duty trucks and buses powered by diesel engines. It is designed to be used in conjunction with smokemeters using the light extinction principle of smoke measurement.

This procedure describes how the snap-acceleration test is to be performed. It also gives specifications for the smokemeter and other test instrumentation and describes the algorithm for the measurement and quantification of the exhaust smoke produced during the test. Included are discussions of factors which influence snap-acceleration test results and methods to correct for these conditions. Unless otherwise noted, these correction methodologies are to be considered an integral part of the snap-acceleration test procedure.

- 1.1 **Purpose**—This document provides a procedure for assessing smoke emissions from in-use vehicles powered by heavy-duty diesel engines. Testing conducted in accordance with this procedure, in combination with reference smoke values, is intended to provide an indication of the state of maintenance and/or tampering of the engine and fuel system relative to the parameters which affect exhaust smoke. The procedure is expected to be of use to regulatory and enforcement authorities responsible for controlling smoke emissions from heavy-duty diesel-powered vehicles, and to heavy-duty vehicle maintenance and repair facilities. However, the procedure as written does not replicate the federal engine certification smoke cycle, and is intended to identify gross emitters. Regulatory agencies using this procedure must establish pass/fail criteria since SAE by-laws prohibit assignment of such criteria.

2. References

- 2.1 **Applicable Publications**—The following publications form a part of this specification to the extent specified herein. Unless otherwise specified, the latest issue of SAE publications shall apply.

- 2.1.1 SAE PUBLICATIONS—Available from SAE, 400 Commonwealth Drive, Warrendale, PA 15096-0001.

SAE J1349—Engine Power Test Code—Spark Ignition and Compression Ignition—Net Power Rating
SAE J1995—Engine Power Test Code—Spark Ignition and Compression Ignition—Gross Power Rating

- 2.2 **Related Publications**—The following publications are provided for information purposes only and are not a required part of this document.

- 2.2.1 SAE PUBLICATIONS—Available from SAE, 400 Commonwealth Drive, Warrendale, PA 15096-0001.

SAE J255a—Diesel Engine Smoke Measurement
SAE J1243—Diesel Emission Production Audit Test Procedure

- 2.2.2 ISO PUBLICATION—Available from ANSI, 11 West 42nd Street, New York, NY 10036-8002.

ISO CD 11614—Apparatus for the Measurement of the Opacity of the Light Absorption Coefficient of Exhaust Gas from Internal Combustion Engines

2.2.3 FEDERAL PUBLICATION—U. S. Government, DOD SSP, Subscription Service Division, Building 4D, 700 Robbins Avenue, Philadelphia, PA 19111-5094

Code of Federal Regulations (CFR), Title 40, Part 86, Subpart I—Emission Regulation for New Diesel Heavy-Duty Engines: Smoke Exhaust Test Procedure

2.3 Other Publications

Procedures for Demonstrating Correlation Among Smokemeters

3. Definitions

3.1 **Diesel Smoke**—Particles, including aerosols, suspended in the exhaust stream of a diesel engine which absorb, reflect, or refract light.

3.2 **Transmittance (T)**—The fraction of light transmitted from a source which reaches a light detector.

3.3 **Opacity (N)**—The percentage of light transmitted from a source which is prevented from reaching a light detector. See Equation 1.

$$\text{Opacity \%} = 100 * (1 - \text{Transmittance}) \quad (\text{Eq. 1})$$

3.4 **Effective Optical Path Length (L) or (EOPL)**—The length of the smoke obscured optical path between the smokemeter light source and detector. Note that portions of the total light source to detector path length which are not smoke obscured do not contribute to the effective optical path length.

3.5 **Smoke Density (K)**—(also known as “Light Extinction Coefficient” and “Light Absorption Coefficient”) A fundamental means of quantifying the ability of a smoke plume or smoke containing gas sample to obscure light. By convention, smoke density is expressed on a per meter basis (m⁻¹). The smoke density is a function of the number of smoke particles per unit gas volume, the size distribution of the smoke particles, and the light absorption and scattering properties of the particles. In the absence of blue or white smoke, the size distribution and the light absorption/scattering properties are similar for all diesel exhaust gas samples and the smoke density is primarily a function of the smoke particle density.

3.6 **Beer-Lambert Law**—A mathematical equation describing the physical relationships between the smoke density (K) and the smoke parameters of transmittance (T), and effective optical path length (L). Because smoke density (K) cannot be measured directly, the Beer-Lambert equation is used to calculate (K), when opacity (N) and EOPL (L) are known.

3.7 **Smoke Opacimeter**—A type of smokemeter designed to measure the opacity of a plume or sample of smoke by means of a light extinction principle.

3.8 **Full-Flow End-of-Line Smokemeter**—A smokemeter which measures the opacity of the full exhaust plume as it exits the tailpipe. The light source and detector for this type of smokemeter are located on opposite sides of the smoke plume and in close proximity to the open end of the tailpipe. When applying this type of smokemeter, the effective optical path length is a function of the tailpipe design.

3.9 **Sampling Type Smokemeter (Also called Partial Flow Smokemeter)**—A smokemeter which continually samples a representative portion of the total exhaust flow and directs it to a measurement cell. With this type of smokemeter, the effective optical path length is a function of the smokemeter design.

3.10 **Smokemeter Measurement Zone**—The effective length between the smokemeter light source and light detector through which exhaust gases pass and interact with the smokemeter light beam.

3.11 Smokemeter Response Time—See 6.3 and Appendix A.

3.12 Smokemeter Linearity—A measure of the maximum absolute deviation of values measured by the smokemeter from the reference values.

4. Special Notes and Conventions

4.1 The term smokemeter is a broad term which applies to all smoke-measuring devices regardless of the smoke-sensing technique employed. Throughout this document, the term smokemeter will refer only to opacimeter type smokemeters.

4.2 To fully describe the light obscuration properties of a smoke sample (i.e., smoke density), opacity (N) must always be associated with an EOPL. Whenever specific smoke opacity values are referenced in this document, the associated effective optical path length is understood to be 0.127 m (5 in).

5. Snap-Acceleration Test—The complete Snap-Acceleration process consists of five phases. These phases are:

- a. Vehicle Preparation and Safety Check
- b. Test Preparation and Equipment Set-up
- c. Driver Familiarization and Vehicle Preconditioning
- d. Execution of the Snap-Acceleration Test
- e. Calculation and Reporting of Final Results

5.1 Vehicle Preparation and Safety Check—Prior to conducting the snap-acceleration test, the following items must be completed:

- a. If the vehicle is equipped with a manual transmission, the transmission must be placed in neutral and the clutch must be released.
If the vehicle is equipped with an automatic transmission, the transmission must be placed in the park position, if available, or otherwise in the neutral position.
- b. The vehicle wheels must be chocked or the vehicle must be otherwise restrained to prevent the vehicle from moving during the testing.
- c. Vehicle air conditioning should be turned off.
- d. If the engine is equipped with an engine brake, it must be deactivated during the snap-acceleration testing.
- e. All devices installed on the engine or vehicle which alter the normal acceleration characteristics of the engine and have the effect of temporarily lowering snap-acceleration test results, or preventing the test from being successfully completed, shall be deactivated prior to testing.
- f. Verify the speed-limiting capability of the engine governor using the following procedure:
With the engine at low idle, slowly depress the engine throttle and allow the engine speed to gradually increase toward its maximum governed high idle speed. As the engine speed increases, carefully note any visual or audible indications that the engine or vehicle may be of questionable soundness. If there are no indications of problems, allow the engine speed to increase to the point that it is possible to verify that the speed-limiting capability of the governor is functioning. Should there be any indication that the speed-limiting capability of the governor is not functioning, or that potential engine damage, or unsafe conditions for personnel or equipment may occur, the throttle should immediately be released and the snap-acceleration testing of the vehicle shall be aborted.
- g. The vehicle should be inspected for exhaust leaks. Severe leaks in the system may cause the introduction of air into the exhaust stream which may cause erroneously low test results.
- h. Users must be cautioned regarding the observance of blue or white smoke in the exhaust. Blue smoke can be an indicator of unburned hydrocarbons (possible oil burning or malfunctioning nozzle), and white smoke can be an indicator of water vapor (possible internal coolant leaking conditions).

5.2 Test Preparation and Equipment Set-up

5.2.1 AMBIENT AIR TEST CONDITIONS—Ambient air conditions can affect snap-acceleration smoke test results. To ensure reliable results, the correction factors in Appendix B should be applied to snap-acceleration testing results to account for normal changes in ambient conditions. However, these correction factors must be applied under the following conditions.

- a. Altitude—Greater than 457 m (1500 ft) above sea level.
- b. Air Temperature—Above or below the range of 2 to 30 x °C (36 to 86 x °F).
- c. Wind—Excessively windy conditions should be avoided. Winds are excessive if they disturb the size, shape, or location of the vehicle exhaust plume in the region where exhaust samples are drawn or where the smoke plume is measured. The effect of wind may be eliminated or reduced by locating the vehicle in a wind-sheltered area or by using measuring equipment designs which preclude wind effects on the smoke in the measuring or sampling zones.
- d. Dry Air Density—If the correction factors referenced in Appendix B are used, the useful range of dry air densities are: 0.908 to 1.235 kg/m³ (0.0567 to 0.0771 lbm/ft³). This range of dry air densities is based on air densities experienced during ambient conditions testing.
- e. Humidity—No visible humidity (including fog, rain, and snow) in the region where exhaust samples are drawn or the smoke plume is measured. Some equipment designs preclude the effects of these conditions.

5.2.2 SMOKEMETER INSTALLATION—The smokemeter and other test equipment used for snap-acceleration tests shall meet the specifications of 6.1 through 6.5. The general installation procedures specified by the smokemeter manufacturer shall be followed when preparing to test a vehicle.

In addition, these special installation procedures shall be followed:

- a. If the test results are to be reported in units of smoke opacity, the rated power of the engine should be determined. The rated power is needed to define the standard effective optical path length used to correct the as-measured smoke opacity to standard conditions as described in Appendix C. The rated power should be available from the tune-up label fixed to the engine or from literature supplied to the owner by the engine manufacturer. In some cases, particularly under roadside test conditions, it may not be possible to readily determine the rated engine power. In these cases, it is recommended that the OD of the vehicle tailpipe section be determined and used as the standard effective optical path length for the purposes of the Beer-Lambert corrections described in Appendix C. If the rated engine power becomes available after the test is run, the test result should be recorrected as necessary using Equation C3 and the appropriate standard effective optical path length from Table C1. Sampling in or immediately downstream of bends such as curved stack outlets in the exhaust pipe may cause some variability between individual Snap-Acceleration cycle readings.
- b. For Full Flow End-of-Line Type Smokemeters—The axis of the smokemeter light beam shall be perpendicular to the axis of the exhaust flow. The centerline of the light beam axis should be located as close as possible, but in no case further than 7 cm (2.76 in) from the exhaust outlet. Appendix D provides additional guidance for smokemeter replacement. Determine the effective optical path length used to make the smoke measurements. For straight tailpipes of circular cross section, the effective optical path length is equal to the tailpipe ID, and for tubing construction can be reasonably approximated by the tailpipe OD. Appendix D provides guidance for determining the as-measured effective optical path length when irregular tailpipe configurations are encountered. The as-measured effective optical path length is required to convert measured smoke values to standard corrected smoke values using the procedures described in Appendix C.

- c. For Sampling Type Smokemeters—The probe of the sampling type smokemeter shall be inserted into the exhaust tailpipe with the open end facing upstream and into the exhaust flow. The clearance between the inside edge of the open end of the sample probe and the tailpipe wall must be at least 5 mm (0.197 in). Only the probe and sampling pipe, or tubing, specified by the manufacturer of the smokemeter shall be used for the smoke sampling. Manufacturer's recommendations regarding the length of the sample line shall be adhered to.
- d. Multiple Exhaust Outlets—When testing vehicles equipped with multiple exhaust outlets, such as dual exhaust systems originating from a single manifold or single pipe, it is normally not necessary to measure the smoke from each exhaust outlet. The following approach is suggested. If there is no discernible difference in the exhaust smoke exiting from each multiple exhaust outlet, the smoke should be measured from the exhaust outlet that provides the most convenient meter installation. A visual observation of one or more preliminary snap-acceleration test cycles should be sufficient to make this determination. Should there be a discernible difference in the smoke exiting from the multiple exhaust outlets, install the smokemeter and conduct the snap-acceleration test on the exhaust outlet that visually appears to have the highest smoke level.

5.2.3 A tachometer to measure the engine speed may be installed and calibrated per the manufacturer's recommendations. A tachometer provides useful data regarding idle RPM, maximum engine RPM, the time necessary for the operator to accelerate the engine from idle to maximum RPM, and the time the engine speed was held at maximum RPM. This information helps to ensure repeatability between test cycles.

5.3 Driver Familiarization and Vehicle Preconditioning

- 5.3.1 Prior to the preconditioning test, the vehicle should be operated under load for at least 15 min to ensure that the engine is warmed-up. Alternatively, vehicle water and oil temperature gages may be checked to verify that the engine is within its normal operating temperature range.
- 5.3.2 SNAP-ACCELERATION CYCLE—The vehicle operator shall be instructed on the proper execution of the snap-acceleration test sequence. It is of critical importance that the vehicle operator fully understand the proper movement of the vehicle throttle during the testing.

With the vehicle conditioned as in 5.1 and with the engine warmed-up and at low idle speed:

- a. The operator shall move the throttle to the fully open position as rapidly as possible.
 - b. The operator shall hold the throttle in the fully open position until the time the engine reaches its maximum governed speed, plus an additional 1 to 4 s.
 - c. Upon completion of the 1 to 4 s with the engine at its maximum governed speed, the operator shall release the throttle and allow the engine to return to the low idle speed.
 - d. Once the engine reaches its low idle speed, the operator shall allow the engine to remain at idle for a minimum of 5 s, but no longer than 45 s, before initiating the next snap-acceleration test cycle. The time period at low idle allows the engine's turbocharger (if so equipped) to decelerate to its normal speed at engine idle. This helps to reduce the smoke variability between snap-acceleration cycles.
 - e. Steps (a) through (d) shall be repeated as necessary to complete the preliminary snap-acceleration cycles and the snap-acceleration test cycles described in 5.3.3 and 5.4.2.
- 5.3.3 PRELIMINARY SNAP-ACCELERATION TEST CYCLES—The vehicle shall receive at least three preliminary snap-acceleration test cycles using the sequence described in 5.3.2. The preliminary cycles allow the vehicle operator to become familiar with the proper throttle movement, and also remove any loose soot which may have accumulated in the vehicle exhaust system during prior operation.

If smoke measurements are made during the preliminary cycles, the preliminary cycles can also provide the opportunity to check for proper operation of the smoke measurement system, and to check if the test validation criteria of 5.4.4 can be met. In this case, the data-processing unit and the smokemeter zero and full scale should first be set according to 5.4.1 and 5.4.2.

5.4 Execution of the Snap-Acceleration Test

5.4.1 DATA PROCESSING UNIT SET-UP—Before snap-acceleration testing can proceed, the smokemeter data processing unit must be properly set up. The operating instructions supplied by the processing unit manufacturer should be consulted for specific set-up procedures; however, the following functional steps must be accomplished.

- a. If a multi-mode test system is used, the appropriate mode for snap-acceleration testing must be selected.
- b. The desired smoke output units (opacity or smoke density) must be selected.
- c. If the Beer-Lambert corrections as described in Appendix C are to be performed within the data-processing unit, values must be supplied for the standard and as-measured effective optical path lengths if opacity output is desired and for the as-measured effective optical path lengths if smoke density output is desired. Appendices C and D provide guidance in determining these input values.
- d. If a red LED smokemeter light source is used and light source wavelength corrections are to be performed within the data-processing unit, the appropriate selections must be made to trigger these calculations (see Appendix C).
- e. If the ambient condition corrections described in Appendix B are to be performed automatically by the data-processing unit, the appropriate ambient parameters must be input.
- f. Any additional test identification information consistent with the needs of the test program and capabilities of the data-processing unit should be supplied at this time. Normally this would include the test date, test operator, vehicle identification, and other such information.

5.4.2 SMOKEMETER ZERO AND FULL SCALE—Prior to conducting smoke measurements, the zero and full scale readings of the smokemeter shall be verified. (Some meter systems may automatically perform the zero and full scale checks. For other meters, this sequence will need to be done manually.) Should optional recording devices be part of the test set-up, this equipment should also be checked for proper operation and calibration.

- a. Smokemeter Warm-up—Prior to any zero and/or full-scale checks or adjustments, the smokemeter shall be warmed up and stabilized according to the manufacturer's recommendations. If the smokemeter is equipped with a purge air system to prevent sooting of the meter optics, this system should also be activated and adjusted according to the manufacturer's recommendations.
- b. Smokemeter Zero—With the smokemeter in the Opacity readout mode, and with no blockage of the smokemeter light beam, adjust the readout to display $0.0\% \pm 1.0\%$ opacity.
- c. Smokemeter Full Scale—With the smokemeter in the Opacity readout mode, and all light prevented from reaching the detector, adjust the readout of the smokemeter to display $100.0\% \pm 1.0\%$ opacity.

NOTE—For Smokemeter readouts in units of Smoke Density (K).

Smoke density (K) is a calculation based upon opacity and EOPL. The opacity scale offers two truly definable calibration points, namely 0% opacity and 100% opacity. The upper end of the smoke density scale is infinite, which makes this point on the K scale undefined. Because of this, the preferred method to set the zero and full scale of the meter when measuring in either smoke density (K) or opacity (N) units is to set the meter to the opacity readout mode and make the zero and full-scale adjustments as described in 5.4.2 (a) to (c). The smoke density would then be correctly calculated based upon the measured opacity and, of course, the EOPL, when the meter is returned to the smoke density readout mode for testing.

However, if this technique is not possible, it is acceptable to set the zero and span of the smokemeter in units of smoke density (K) with the use of a neutral density filter of known value. Should this be the case, the smokemeter zero and span shall be set as follows:

SAE J1667 Issued FEB96

- d. Smokemeter Zero—With the smokemeter in the Smoke Density (K) readout mode, and with no blockage of the smokemeter light beam, adjust the readout to display $0.00 \text{ m}^{-1} \pm 0.10 \text{ m}^{-1}$.
- e. Smokemeter Span (If required by the smokemeter manufacturer)—With the smokemeter in the Smoke Density (K) readout mode, place a neutral density filter of known value between the light emitter and detector. The neutral density filter shall meet the accuracy requirements of 6.2.10 and have a known nominal value in the range of 1.5 to 5.5 m^{-1} . Adjust the smokemeter readout to display the filter nominal value, $\pm 0.10 \text{ m}^{-1}$.

NOTE—Neutral density calibration filters are precision devices and can easily be damaged during use. Handling should be minimized and, when required, should be done with care to avoid scratching or dirtying of the filter.

- 5.4.3 SNAP-ACCELERATION TEST CYCLES—Within 2 min of the execution of the preliminary snap-acceleration cycles, conduct three snap-acceleration test cycles, actuating the vehicle throttle in the manner and sequence described in 5.3.2 (a to e).

Determine the corrected maximum 0.5 s average smoke values for each of the three snap-acceleration cycles using the smoke data processing algorithms described in Appendices A and C.

At the conclusion of the test sequence, and where needed as per manufacturer's recommendation, determine the degree of smokemeter zero shift by eliminating all exhaust from between the smokemeter light source and detector and noting the smokemeter display.

- 5.4.4 TEST VALIDATION CRITERIA—The test results from 5.4.3 shall be considered valid only after the following criteria have been met.

- a. The post-test smokemeter zero shift values shall not exceed:
 - 1. $\pm 2.0\%$ opacity—For smoke measurements made in opacity.
 - 2. $\pm 0.15 \text{ m}^{-1}$ —For smoke measurements made in smoke density (K).
- b. The arithmetical difference between the highest and lowest corrected maximum 0.5 s average smoke values from the three test cycles shall not exceed:
 - 1. 5.0% opacity—For smoke measurements made in opacity.
 - 2. 0.50 m^{-1} —For smoke measurements made in smoke density (K).

- 5.4.5 INVALID TESTS—Should the smoke test data from 5.4.3 not meet the test validation criteria of 5.4.4, the following items should be checked as possible causes for the invalid test results:

- a. If the engine did not meet the operating temperature requirements, run the engine/vehicle under load for at least 15 min or until the vehicle oil and water temperature gages indicate that normal engine operating temperatures have been achieved. Return to 5.2.2 (Smokemeter Installation) and repeat the test sequence.
- b. If improper or inconsistent application of the vehicle throttle is suspected, re-instruct the vehicle operator as to the proper execution of the snap-acceleration test, especially the movement of the vehicle throttle, as detailed in 5.3.2. Continue on with the procedure at this point and repeat the preliminary test cycles and the snap-acceleration test sequence while observing the vehicle operator.
- c. Check the smokemeter, its installation on the tailpipe, and any support instrumentation for possible malfunctions. Correct as necessary and then return to 5.3.3 (Preliminary Snap-Acceleration Test Cycles), and repeat the test sequence.

- d. If the post-test smokemeter zero check was exceeded due to positive zero drift, the probable cause is soot accumulation on the smokemeter optics. It is recommended that the snap-acceleration test sequence be repeated and while doing so, the smokemeter zero may be readjusted during the low idle period between each of the snap-acceleration test cycles. If the measured low idle smoke level of the vehicle is less than 2.0% opacity or 0.20 m^{-1} smoke density, it is permissible to re-zero the meter while it remains exposed to the vehicle exhaust. If the idle smoke level exceeds these limits, it is necessary to discontinue exposure to exhaust before rezeroing the meter.

It is not necessary to complete an invalid test before employing the rezeroing technique discussed previously. If comparison of the low idle smoke readings shows an increasing trend from one test cycle to the next, sooting of meter optics can be suspected and the rezeroing technique can immediately be used.

If it is not possible to rezero the meter, the meter optics should be cleaned per the smokemeter manufacturer's recommended procedures and the test sequence should be repeated beginning at 5.3.3 (preliminary snap-acceleration test cycles). If zero drift and rezeroing difficulties persist, it is recommended that the meter purge air system (if so equipped) be checked for proper operation.

- e. If the procedure has been repeated in accordance with the requirements stated in 5.4.5 (a to d), and the test results still cannot be obtained that conform with the test validation criteria, then it is likely that the engine is in need of service.

5.5 Calculation and Reporting of Final Test Result—If the validation criteria of 5.4.4 are met, the data shall be deemed valid and the test complete. The average of the corrected maximum 0.5 s average smoke values from the three snap-acceleration test cycles shall be computed and reported as the final test result. (See Appendix A.)

6. Test Instrumentation Specifications—This section provides specifications for the required and optional test equipment used in the snap-acceleration test.

6.1 General Requirements for the Smoke Measurement Equipment—The snap-acceleration smoke test requires the use of a smoke measurement and data-processing system which includes three functional units. These units may be integrated into a single component or provided as a system of interconnected components. The three functional units are:

- a. A full-flow end-of-line or a sampling type smokemeter meeting the specifications of 6.2 through 6.4.
- b. A data-processing unit capable of performing the functions described in Appendices A and C.
- c. A printer and/or electronic storage medium to record and output the individual corrected maximum 0.5 s average smoke values from each snap-acceleration test cycle, and the final average snap-acceleration test result.

6.2 Specific Requirements for the Smoke Measurement Equipment

6.2.1 LINEARITY— $\pm 2\%$ opacity or $\pm 0.30 \text{ m}^{-1}$ density.

6.2.2 ZERO DRIFT RATE—Not to exceed $\pm 1\%$ opacity/hour.

6.3 Instrument Response Time Requirements

6.3.1 OVERALL INSTRUMENT RESPONSE TIME REQUIREMENT—The overall instrument response time (t) shall be: $0.500 \text{ s} \pm 0.015 \text{ s}$. It is defined as the difference between the times when the output of the smokemeter reaches 10% and 90% of full scale when the opacity of the gas being measured is changed in less than 0.01 s.

It shall include all the physical, electrical, and filter response times. Mathematically, it is represented by Equation 2. (See Appendix A for a more detailed methodology and an example calculation.)

$$t = \text{SQRT}(t_p^2 + t_e^2 + t_f^2) \quad (\text{Eq. 2})$$

where:

- t_p = The physical response time
- t_e = The electrical response time
- t_f = The filter response time

- 6.3.2 PHYSICAL RESPONSE TIME (t_p)—This is the difference between the times when the output of a rapid response receiver (with a response time of not more than 0.01 s) reaches 10% and 90% of the full deviation when the opacity of the gas being measured is changed in less than 0.1 s.

The physical response time is defined for the smokemeter only and excludes the probe and sample line. However, on some in-use smokemeter systems, the probe and sample line may significantly affect the overall response time of the system. If necessary, this shall be taken into account for any particular smokemeter system.

For full-flow type smokemeters, the response time is a function of the velocity of flow in the vehicle exhaust pipe and the path length across the detector (detector diameter). It can be assumed equal to a negligible 0.01 s. For sampling type smokemeters where the measuring zone is a straight section of pipe of uniform diameter, the physical response can be estimated by Equation 3:

$$t = 0.8 \cdot V/Q \quad (\text{Eq. 3})$$

where:

- Q = The rate of flow of gas through the measuring zone
- V = The volume of the measuring zone

For such instruments, the speed of the gas through the measuring zone shall not differ by more than 50% from the average speed over 90% of the length of the measuring zone.

For all smokemeters, if the physical response calculates greater than 0.2 s, then the response time shall be measured.

- 6.3.3 ELECTRICAL RESPONSE TIME (t_e)—It is defined as the time needed for the recorder output to go from 10% of the maximum scale to 90% of the maximum scale value when a fully opaque screen is placed in front of the photo cell in less than 0.01 s, or the LED is turned off. This is to include all of the effects of recorder output response time.

- 6.3.4 FILTER RESPONSE TIME (t_f)—Filtering of the smoke signal will be necessary on most smokemeters to achieve an overall response time of $0.500 \text{ s} \pm 0.015 \text{ s}$. Most smokemeters have a very fast electrical response time, but physical response times will vary from one device to the next depending on design and gas flow.

Appendix A specifies the recommended second-order digital filtering algorithm to be used.

- 6.3.5 DETERMINATION OF THE PEAK SMOKE VALUE—An algorithm in Appendix A shall be used to determine the reported peak exhaust smoke levels.

6.4 Smokemeter Light Source and Detector

- 6.4.1 LIGHT SOURCE—The light source shall be an incandescent lamp with a color temperature in the range of 2800 to 3250 °K, or a green light emitting diode (LED) with a spectral peak between 550 and 570 nm.

Alternatively, a red LED may be used provided that the appropriate light wavelength correction is made as described in Appendix C.

SAE J1667 Issued FEB96

- 6.4.2 LIGHT DETECTOR—The light detector shall be a photocell or a photodiode (with a filter, if necessary). In the case of an incandescent light source, the detector shall have a peak spectral response in the range of 550 to 570 nm, and shall have a gradual reduction in response to values of less than 4% of the peak response value below 430 nm and above 680 nm.
- 6.4.3 The rays of the light beam shall be parallel within a tolerance of 3 degrees of the optical axis. The detector shall be designed such that it is not affected by direct or indirect light rays with an angle of incidence greater than 3 degrees to the optical axis.
- 6.4.4 Any method such as purge air which is used to protect the light source and detector from direct contact with exhaust soot shall be designed to minimize any unknown effect on the effective optical path length of the measured smoke (see C.5.1). For full-flow end-of-line smokemeters, the protection feature must not cause the smoke plume to be distorted by more than 0.5 cm. For sampling type smokemeters, the meter manufacturer must account for any effect of the protection feature in specifying the effective optical path length of the meter.
- 6.4.5 The sampling and digitization rate of the data processing units shall be at least 20 Hz (i.e., at least 10 data samples per 0.5 s interval). Additionally, the product of the data sampling time increment (seconds) and one half the data sample rate (Hz) rounded to the next higher integer value must be within the range of 0.500 to 0.510 s.

6.5 Specifications for Auxiliary Test Equipment

- 6.5.1 NEUTRAL DENSITY FILTERS—Any neutral density filter used in conjunction with smokemeter calibration, linearity measurements, or setting span shall have its value known to within 0.5% opacity or 0.04 m^{-1} . The filter's named value must be checked for accuracy at least yearly using a reference traceable to a national standard.
- 6.5.2 If altitude correction (i.e., the altitude is greater than 457 m (1500 ft)) then:
- Equipment used to measure barometric pressure must be accurate within $\pm 0.30 \text{ kPa}$ ($\pm 0.089 \text{ in-Hg}$)
 - Ambient dry bulb temperature must be accurate within $\pm 2 \text{ }^\circ\text{C}$ ($\pm 3.6 \text{ }^\circ\text{F}$)
- 6.5.3 Measurement of the following parameters is optional; however, if measured, the specified accuracy requirements should be met:
- Ambient Dry Bulb Temperature— $\pm 2 \text{ }^\circ\text{C}$ ($\pm 3.6 \text{ }^\circ\text{F}$)
 - Dew Point Temperature— $\pm 2 \text{ }^\circ\text{C}$ ($\pm 3.6 \text{ }^\circ\text{F}$)
 - Engine Speed— $\pm 100 \text{ rpm}$
- 6.5.4 OPTIONAL RECORDING DEVICES—A supplemental chart recorder or other collection media may be used provided that the device(s) does not affect the smoke measurement.
7. **Smokemeter Maintenance and Calibration**—The smokemeter should be maintained and serviced per the manufacturer's recommendations. In addition to the zero and span adjustments to be made prior to each snap-acceleration test (5.4.2), the linearity of the meter response should be periodically checked as per manufacturer's recommendations in the range of measurement interest using neutral density filters meeting the requirements of 6.5.1. Non-linearities in excess of 2% opacity or 0.30 m^{-1} smoke density should be corrected prior to resuming testing with the meter.

PREPARED BY THE SAE HEAVY-DUTY IN-USE EMISSION STANDARDS COMMITTEE

APPENDIX A

SECOND-ORDER FILTER ALGORITHM USED TO CALCULATE A
MAXIMUM 0.500 S AVERAGE SMOKE VALUE

A.1 Introduction—This appendix explains how to create and use the recommended Bessel low-pass digital filter algorithm in a smokemeter to filter out the high-frequency smoke readings which are produced during a snap-acceleration test. This appendix in particular describes the methodology used to design a low-pass second-order Bessel filter with a response time as needed for a particular smokemeter application. This appendix also describes the procedure for determining the final snap-acceleration test. Two example calculations detailing the selection of Bessel filter coefficients and their use are also provided in this appendix to illustrate the concepts more clearly.

The digital Bessel filter described in this appendix is a second-order (2-pole) low-pass digital filter algorithm. It is the recommended filter to be used for designing smokemeters with 0.500 s overall response times as required in 6.3. The Bessel filter type was chosen because it allows passage of all signals which do not change very much with time, but effectively blocks all signals with higher-frequency components. Its linear-phase characteristics also enable it to approximate a constant time delay over a limited frequency range. Transient waveforms can also be passed with minimal distortion when it is used as a running average type filter. A digital approach was chosen due to the relative ease of implementing a software algorithm in most smokemeters. However, analog Bessel filters using the appropriate electronic circuits may also be used.

A.2 Definitions

- B = Bessel parameter constant. It equals $[\text{Sqrt}(5)-1]/2$
- f_c = Bessel cutoff frequency used to control the filtered response
- t_e = Electrical response time of the smokemeter (seconds)
- t_F = Filter response time (seconds)
- t_{Fd} = Desired filter response time (seconds)
- t_p = Physical response time of the smokemeter (seconds)
- t_{10} = The test time when the output response to an input step response is equal to 10% of the step input
- t_{90} = The test time when the output response to an input step response is equal to 90% of the step input
- Δ_t = Time between two stored opacity values (i.e., sampling period (seconds))
- X_i = Bessel filter input at sample number (i)
- X_{i-1} = Bessel filter input at sample number (i-1)
- X_{i-2} = Bessel filter input at sample number (i-2)
- Y_i = Bessel filter output at sample number (i)
- Y_{i-1} = Bessel filter output at sample number (i-1)
- Y_{i-2} = Bessel filter output at sample number (i-2)

A.3 Designing a Bessel Low-Pass Filter—Designing the 0.500 s Bessel low-pass digital filter is a multistep process which may involve several iterative calculations to determine coefficients. This section provides a method for determining the desired amount of filtering for smokemeters with different electrical and physical response times, or different sample rates. Bessel filters can be designed to accommodate filter designs having response times ranging from 0.010 to 0.500 s, and digitization rates of 50 Hz and higher.

It is recommended that all Bessel filter calculations be performed in opacity units for the sake of consistency between smokemeters. If smokemeter output in units of density need to be reported, the Beer-Lambert law may be used to convert the final opacity results to density results, and perform any necessary stack size correction. This conversion should be done only after all Bessel filter equations have been performed due to the non-linearity of the Beer-Lambert law.

A.3.1 Calculating the Desired Filter Response Time (t_{Fd})—Prior to designing a digital Bessel filter, it is necessary to determine the physical response time (t_p) and the electrical response time (t_e) for the relevant smokemeter. These parameters are necessary in order to determine how much electronic filtering is necessary to achieve an overall 0.500 s response time. For some partial flow smokemeters this may require experimental data. For other smokemeters the procedures and equations in 6.3 may be used.

Once the values of t_p and t_e are known, the desired filter response time (t_{Fd}) can be determined by using Equation A1.

$$t_{Fd} = \text{SQRT}[0.500^2 - (t_p^2 + t_e^2)] \quad (\text{Eq. A1})$$

A.3.2 Estimating Bessel Filter Cutoff Frequency (f_c)—The Bessel filter response time (t_F) is defined as the time in which the output signal (Y_i) reaches 10% (Y_{10}) and 90% (Y_{90}) of a full-scale input step (X_i) which occurs in less than 0.01 s. The difference in time between the 90% response (t_{90}) and the 10% response time (t_{10}) defines the response time (t_F). Thus,

$$t_F = t_{90} - t_{10} \quad (\text{Eq. A2})$$

For the filter to operate properly, the filter response time (t_F) should be within 1% of the desired response time (t_{Fd}), that is, $[(t_F) - (t_{Fd})] < [0.01 * (t_{Fd})]$.

To create a filter where t_F approximates t_{Fd} , the appropriate cutoff frequency (f_c) must be determined. This is an iterative process of choosing successively better values of (f_c) until $[(t_F) - (t_{Fd})] < [0.01 * (t_{Fd})]$.

The first step in the process is to calculate a first guess value for f_c using Equation A3.

$$f_c = \pi / (10 * t_{Fd}) \quad (\text{Eq. A3})$$

The values of B, Ω , C, and K are then calculated using Equation A4 through A7.

$$B = 0.618034 \quad (\text{Eq. A4})$$

$$\Omega = 1 / [\tan(\pi * \Delta t * f_c)] \quad (\text{Eq. A5})$$

$$C = 1 / [1 + \Omega * \text{sqrt}(3 * B) + B * \Omega^2] \quad (\text{Eq. A6})$$

$$K = 2 * C * [B * \Omega^2 - 1] - 1 \quad (\text{Eq. A7})$$

Δt = Time between two stored opacity values (i.e., sampling period (seconds)).

The values of K and C are then used in Equation A8 to calculate the Bessel filter response to the given step input. Because of the recursive nature of Equation A8, the values of X and Y listed as follows are used to begin the process.

$$Y_i = Y_{i-1} + C * [X_i + 2 * X_{i-1} + X_{i-2} - 4 * Y_{i-2}] + K * (Y_{i-1} - Y_{i-2}) \quad (\text{Eq. A8})$$

where:

$$\begin{aligned} X_i &= 100 \\ X_{i-1} &= 0 \\ X_{i-2} &= 0 \\ Y_{i-1} &= 0 \\ Y_{i-2} &= 0 \end{aligned}$$

As shown in the example (A.7.1), calculate Y_i for successive values of $X_i = 100$ until the value of Y_i has exceeded 90% of the step input (X_i). The difference in time between the 90% response (t_{90}) and the 10% response (t_{10}) defines the response time (t_F) for that value of (f_c). Since the data are digital, linear interpolation may be needed to precisely calculate t_{10} and t_{90} .

If the response time is not close enough to the desired response time {that is, if $[(t_F)-(t_{Fd})] > [0.01*(t_{Fd})]$ }, then the iterative process must be repeated with a new value of (f_c). The variables (t_F) and (f_c) are approximately proportional to each other, so the new (f_c) should be selected based on the difference between (t_F) and (t_{Fd}) as shown in the example calculations (A.5.1).

A.4 Using the Bessel Filter Algorithm—The proper cutoff frequency (f_c) is the one that produces the desired filter response time (t_{Fd}). Once this frequency has been determined through the iterative process, the proper Bessel filter algorithm coefficients for Equation A4 through A7 are specified. Equation A8 and the coefficients can then be programmed into the smokemeter to produce the desired filter.

The Bessel filter equation (Equation A8) is recursive in nature. Thus, it needs some initial input values of X_{i-1} and X_{i-2} and initial output values Y_{i-1} and Y_{i-2} to get the algorithm started. These may be assumed to be 0% opacity. A detailed example calculation is shown in A.7.3.

A.5 Determining the Maximum 0.500 s Averaged Smoke Value—The maximum smoke value for a snap-acceleration test cycle (Y_{max}) is then selected from among the individual Y_i values computed using Equation A8 (after suitable Beer-Lambert and light source wavelength corrections are applied). This is the final test result for the test cycle and is used in combination with the results from the other snap-acceleration cycles in the test to determine a final snap-acceleration test result.

In equation form:

$$Y_{max} = \text{Maximum}(Y_i) \quad (\text{Eq. A9})$$

A.6 Determination of the Final Test Result—If the test validation criteria of 5.4.4 have been met, the final snap-acceleration test result shall be computed by taking the simple average of the three corrected maximum 0.500 s averaged smoke values obtained from the three snap-acceleration test cycles.

$$A = (Y_{max,1} + Y_{max,2} + Y_{max,3})/3 \quad (\text{Eq. A10})$$

A.7 A.7 Example of Incorporating a Bessel Filter Into a Smokemeter Design—This example illustrates how a full flow meter with a fast physical and electrical response time can implement the Bessel filter algorithm. The sample smokemeter has the following characteristics:

- a. Physical Response Time = 0.020 s
- b. Electrical Response Time = 0.010 s
- c. Sampling Rate = 100 Hz
- d. Sampling Period = 0.01 s

A.7.1 First Iteration to Estimate Bessel Function Cutoff Frequency (f_c)—This section displays the initial calculations which are performed to estimate the correct value of the cutoff frequency (f_c).

The results from Equation A1 indicate that the desired filter response (t_{Fd}) is 0.4995 (for simplicity, a value of 0.50 will be used in the sample calculations). This may be typical of a full flow meter with a very fast electrical and physical response time. It suggests that most of the desired 0.500 s filtering will be performed by the digital filter rather than the instrument.

$$t_{Fd} = 0.4995 = \text{SQRT}[0.500^2 - (0.020^2 + 0.010^2)] \quad (\text{Eq. A11})$$

By inserting the correct values of Δt and t_F into Equations A2 through A7, the Bessel function coefficients are determined. These are shown in Table A1.

TABLE A1—INITIAL BESSEL COEFFICIENTS

Equation A1	t_F	0.500
Equation A2	f_c	0.6283
Equation A4	B	0.618
Equation A5	Ω	50.6555063
Equation A6	C	0.00060396
Equation A7	K	0.91427037
	Δt	0.01

The Bessel coefficients can now be inserted into Equation A8 along with the step input function (i.e., an input of 0% opacity to 100% opacity in 0.01 s) to illustrate the effect of the Bessel filter on the step response as a function of time. The input step function is shown as X_i in Table A2. To simulate the step response, input $X_i = 100$. This will create the sudden jump from 0 to 100%.

The Bessel filtered output is shown as Y_i in Table A2. The two output points which are of interest are the 10% response point and the 90% response point. These are the values where Y_i first exceeds 10% and 90%. Since the output Y_i is digital, the exact 10% and 90% points must be interpolated from Table A2. The four points which bound the 10% and 90% points are indicated by an "X" in the Index column of Table A2. These are index numbers 9, 10, and 64, 65.

For this specific case, the following interpolation formulas are used to calculate the values of $t_{10\%}$ and $t_{90\%}$.

$$t_{10\%} = 0.01 * [9 + (10 - 8.647) / (10.260 - 8.647)] = 0.0984s \quad (\text{Eq. A12})$$

$$t_{90\%} = 0.01 * [64 + (90 - 89.834) / (90.427 - 89.834)] = 0.6428s \quad (\text{Eq. A13})$$

Now calculate the difference between $t_{90\%}$ and $t_{10\%}$ and see if it is close enough to t_F (close enough means within 1% or in this case 0.005).

$$0.6428 - 0.0984 = 0.5444s \quad (\text{Eq. A14})$$

The calculation shows that the response time of the filter is 0.5444 s using a value of f_c of 0.6283. The difference between this value and the desired value of 0.50 is 0.0444 which is about 10% greater than desired. Thus, another attempt to reach the desired response time will have to be made. Since 0.5444 is about 10% too high, use a cutoff frequency (f_c) which is 10% larger for the second iteration.

A.7.2 Second Iteration to Estimate Bessel Function Cutoff Frequency (f_c)—For the second iteration, a value of 0.690 is chosen for the value of f_c . This is approximately 10% higher than the value previously used. When this value is used, the Bessel function coefficients in Table A3 are obtained.

The filter responses Y_i were also recalculated for the step input X_i . The entire table of inputs (X_i) and responses (Y_i) (analogous to Table A2) is not shown. However, the values of t_{10} and t_{90} and the difference between were calculated and are shown in Table A4. In this case, the difference between the filter response time and the desired filter response time of 0.50 s is 0.0049. This is less than the 1% difference criteria (0.005 s). Thus, the value of 0.692 for the frequency cutoff (f_c) is the correct one for this smokemeter application.

A.7.3 Sample Calculation of the Bessel Filter Opacity Response—Once the appropriate value for the cutoff frequency (f_c) has been determined, then Equations A4 through A8 are used to calculate the Bessel filtered opacity values (Y_i) for any given input opacity values (X_i). The maximum filtered response is then selected and reported as the smoke reading for that particular snap-acceleration cycle.

TABLE A2—INITIAL SIMULATION OF THE BESSEL FILTER EFFECT (USED TO DETERMINE f_c)

Index	Time	X_i	X_{i-1}	X_{i-2}	Y_i	Y_{i-1}	Y_{i-2}	
	0	0.00	100	0	0	0.060	0.000	0.000
	1	0.01	100	100	0	0.297	0.060	0.000
	2	0.02	100	100	100	0.754	0.297	0.060
	3	0.03	100	100	100	1.414	0.754	0.297
	4	0.04	100	100	100	2.256	1.414	0.754
	5	0.05	100	100	100	3.264	2.256	1.414
	6	0.06	100	100	100	4.423	3.264	2.256
	7	0.07	100	100	100	5.715	4.423	3.264
	8	0.08	100	100	100	7.128	5.715	4.423
X	9	0.09	100	100	100	8.647	7.128	5.715
X	10	0.10	100	100	100	10.260	8.647	7.128
	11	0.11	100	100	100	11.956	10.260	8.647
	12	0.12	100	100	100	13.723	11.956	10.260
	13	0.13	100	100	100	15.552	13.723	11.956
	14	0.14	100	100	100	17.432	15.552	13.723
	15	0.15	100	100	100	19.355	17.432	15.552
	16	0.16	100	100	100	21.312	19.355	17.432
	17	0.17	100	100	100	23.297	21.312	19.355
	18	0.18	100	100	100	25.301	23.297	21.312
	19	0.19	100	100	100	27.319	25.301	23.297
	20	0.20	100	100	100	29.344	27.319	25.301
	21	0.21	100	100	100	31.372	29.344	27.319
	22	0.22	100	100	100	33.396	31.372	29.344
	23	0.23	100	100	100	35.413	33.396	31.372
	24	0.24	100	100	100	37.417	35.413	33.396
	25	0.25	100	100	100	39.406	37.417	35.413
	26	0.26	100	100	100	41.375	39.406	37.417
	27	0.27	100	100	100	43.322	41.375	39.406
	28	0.28	100	100	100	45.244	43.322	41.375
	29	0.29	100	100	100	47.138	45.244	43.322
	30	0.30	100	100	100	49.001	47.138	45.244
	31	0.31	100	100	100	50.833	49.001	47.138
	32	0.32	100	100	100	52.631	50.833	49.001
	33	0.33	100	100	100	54.394	52.631	50.833
	34	0.34	100	100	100	56.119	54.394	52.631
	35	0.35	100	100	100	57.807	56.119	54.394
	36	0.36	100	100	100	59.457	57.807	56.119
	37	0.37	100	100	100	61.067	59.457	57.807
	38	0.38	100	100	100	62.637	61.067	59.457
	39	0.39	100	100	100	64.166	62.637	61.067
	40	0.40	100	100	100	65.654	64.166	62.637
	41	0.41	100	100	100	67.102	65.654	64.166
	42	0.42	100	100	100	68.508	67.102	65.654

**TABLE A2—INITIAL SIMULATION OF THE BESSEL
FILTER EFFECT (USED TO DETERMINE f_c) (CONTINUED)**

Index	Time	X_i	X_{i-1}	X_{i-2}	Y_i	Y_{i-1}	Y_{i-2}
43	0.43	100	100	100	69.873	68.508	67.102
44	0.44	100	100	100	71.198	69.873	68.508
45	0.45	100	100	100	72.481	71.198	69.873
46	0.46	100	100	100	73.724	72.481	71.198
47	0.47	100	100	100	74.927	73.724	72.481
48	0.48	100	100	100	76.090	74.927	73.724
49	0.49	100	100	100	77.215	76.090	74.927
50	0.50	100	100	100	78.300	77.215	76.090
51	0.51	100	100	100	79.348	78.300	77.215
52	0.52	100	100	100	80.358	79.348	78.300
53	0.53	100	100	100	81.331	80.358	79.348
54	0.54	100	100	100	82.269	81.331	80.358
55	0.55	100	100	100	83.171	82.269	81.331
56	0.56	100	100	100	84.039	83.171	82.269
57	0.57	100	100	100	84.872	84.039	83.171
58	0.58	100	100	100	85.673	84.872	84.039
59	0.59	100	100	100	86.442	85.673	84.872
60	0.60	100	100	100	87.180	86.442	85.673
61	0.61	100	100	100	87.887	87.180	86.442
62	0.62	100	100	100	88.564	87.887	87.180
63	0.63	100	100	100	89.213	88.564	87.887
X 64	0.64	100	100	100	89.834	89.213	88.564
X 65	0.65	100	100	100	90.427	89.834	89.213
66	0.66	100	100	100	90.994	90.427	89.834
67	0.67	100	100	100	91.536	90.994	90.427
68	0.68	100	100	100	92.053	91.536	90.994
69	0.69	100	100	100	92.546	92.053	91.536
70	0.70	100	100	100	93.016	92.546	92.053

TABLE A3—FINAL BESSEL COEFFICIENTS

Equation A1	t_F	0.500
Equation A2	f_c	0.6292
Equation A4	B	0.618000
Equation A5	Ω	45.991292
Equation A6	C	0.000729
Equation A7	K	0.905717
	Δt	0.01

**TABLE A4—BOUNDARY RESPONSE TIMES
(SECOND ITERATION)**

$t_{10\%}$	0.09145
$t_{90\%}$	0.5856
$\Delta t_{90\%} - t_{10\%}$	0.4951

SAE J1667 Issued FEB96

Table A5 shows a sample calculation for an actual snap-acceleration smoke event collected at 100 Hz. Only 100 (1 s) readings and calculated values are shown so as to reduce the length of the table. The Bessel coefficients shown in Table A3 are used with Equation A8 to calculate the Bessel filter responses (Y_i) to the raw smoke inputs (X_i).

TABLE A5—BESSEL FILTER EXAMPLE

Time	X_i	X_{i-1}	X_{i-2}	Y_i	Y_{i-1}	Y_{i-2}
0.00	0.00	0.00	0.00	0.000	0.000	0.000
0.01	0.00	0.00	0.00	0.000	0.000	0.000
0.02	0.30	0.00	0.00	0.000	0.000	0.000
0.03	0.60	0.30	0.00	0.001	0.000	0.000
0.04	0.50	0.60	0.30	0.004	0.001	0.000
0.05	0.40	0.50	0.60	0.007	0.004	0.001
0.06	0.30	0.40	0.50	0.012	0.007	0.004
0.07	0.10	0.30	0.40	0.017	0.012	0.007
0.08	0.00	0.10	0.30	0.021	0.017	0.012
0.09	0.00	0.00	0.10	0.026	0.021	0.017
0.10	0.00	0.00	0.00	0.029	0.026	0.021
0.11	0.00	0.00	0.00	0.033	0.029	0.026
0.12	0.00	0.00	0.00	0.036	0.033	0.029
0.13	0.20	0.00	0.00	0.039	0.036	0.033
0.14	0.40	0.20	0.00	0.042	0.039	0.036
0.15	0.40	0.40	0.20	0.045	0.042	0.039
0.16	0.30	0.40	0.40	0.049	0.045	0.042
0.17	0.30	0.30	0.40	0.054	0.049	0.045
0.18	0.70	0.30	0.30	0.059	0.054	0.049
0.19	0.80	0.70	0.30	0.066	0.059	0.054
0.20	0.70	0.80	0.70	0.073	0.066	0.059
0.21	0.40	0.70	0.80	0.082	0.073	0.066
0.22	0.20	0.40	0.70	0.091	0.082	0.073
0.23	0.20	0.20	0.40	0.100	0.091	0.082
0.24	0.30	0.20	0.20	0.108	0.100	0.091
0.25	0.50	0.30	0.20	0.116	0.108	0.100
0.26	0.40	0.50	0.30	0.124	0.116	0.108
0.27	0.20	0.40	0.50	0.133	0.124	0.116
0.28	0.00	0.20	0.40	0.140	0.133	0.124
0.29	0.40	0.00	0.20	0.147	0.140	0.133
0.30	0.30	0.40	0.00	0.154	0.147	0.140
0.31	0.20	0.30	0.40	0.161	0.154	0.147
0.32	0.20	0.20	0.30	0.167	0.161	0.154
0.33	0.10	0.20	0.20	0.172	0.167	0.161
0.34	0.10	0.10	0.20	0.177	0.172	0.167
0.35	0.30	0.10	0.10	0.182	0.177	0.172
0.36	0.70	0.30	0.10	0.186	0.182	0.177
0.37	1.10	0.70	0.30	0.192	0.186	0.182
0.38	2.60	1.10	0.70	0.200	0.192	0.186
0.39	3.50	2.60	1.10	0.215	0.200	0.192
0.40	7.10	3.50	2.60	0.239	0.215	0.200
0.41	10.20	7.10	3.50	0.281	0.239	0.215
0.42	15.90	10.20	7.10	0.350	0.281	0.239
0.43	21.80	15.90	10.20	0.458	0.350	0.281

SAE J1667 Issued FEB96

TABLE A5—BESSEL FILTER EXAMPLE (CONTINUED)

Time	X _i	X _{i-1}	X _{i-2}	Y _i	Y _{i-1}	Y _{i-2}
0.44	28.10	21.80	15.90	0.619	0.458	0.350
0.45	34.40	28.10	21.80	0.846	0.619	0.458
0.46	39.90	34.40	28.10	1.149	0.846	0.619
0.47	44.80	39.90	34.40	1.537	1.149	0.846
0.48	50.30	44.80	39.90	2.016	1.537	1.149
0.49	52.70	50.30	44.80	2.590	2.016	1.537
0.50	56.40	52.70	50.30	3.259	2.590	2.016
0.51	58.80	56.40	52.70	4.020	3.259	2.590
0.52	61.50	58.80	56.40	4.873	4.020	3.259
0.53	63.40	61.50	58.80	5.812	4.873	4.020
0.54	64.70	63.40	61.50	6.832	5.812	4.873
0.55	65.00	64.70	63.40	7.928	6.832	5.812
0.56	66.20	65.00	64.70	9.091	7.928	6.832
0.57	66.40	66.20	65.00	10.313	9.091	7.928
0.58	68.30	66.40	66.20	11.589	10.313	9.091
0.59	67.00	68.30	66.40	12.911	11.589	10.313
0.60	66.30	67.00	68.30	14.271	12.911	11.589
0.61	66.40	66.30	67.00	15.659	14.271	12.911
0.62	65.90	66.40	66.30	17.068	15.659	14.271
0.63	66.10	65.90	66.40	18.491	17.068	15.659
0.64	63.50	66.10	65.90	19.921	18.491	17.068
0.65	63.40	63.50	66.10	21.349	19.921	18.491
0.66	61.20	63.40	63.50	22.768	21.349	19.921
0.67	59.90	61.20	63.40	24.170	22.768	21.349
0.68	59.40	59.90	61.20	25.549	24.170	22.768
0.69	58.20	59.40	59.90	26.900	25.549	24.170
0.70	56.60	58.20	59.40	28.218	26.900	25.549
0.71	54.70	56.60	58.20	29.499	28.218	26.900
0.72	53.80	54.70	56.60	30.737	29.499	28.218
0.73	53.40	53.80	54.70	31.930	30.737	29.499
0.74	51.70	53.40	53.80	33.075	31.930	30.737
0.75	50.80	51.70	53.40	34.171	33.075	31.930
0.76	48.80	50.80	51.70	35.214	34.171	33.075
0.77	48.30	48.80	50.80	36.203	35.214	34.171
0.78	45.80	48.30	48.80	37.135	36.203	35.214
0.79	45.30	45.80	48.30	38.009	37.135	36.203
0.80	44.30	45.30	45.80	38.823	38.009	37.135
0.81	42.00	44.30	45.30	39.579	38.823	38.009
0.82	42.20	42.00	44.30	40.274	39.579	38.823
0.83	39.90	42.20	42.00	40.910	40.274	39.579
0.84	39.20	39.90	42.20	41.485	40.910	40.274
0.85	39.10	39.20	39.90	42.002	41.485	40.910
0.86	36.90	39.10	39.20	42.462	42.002	41.485
0.87	36.50	36.90	39.10	42.865	42.462	42.002
0.88	35.20	36.50	36.90	43.211	42.865	42.462
0.89	34.50	35.20	36.50	43.503	43.211	42.865
0.90	34.90	34.50	35.20	43.743	43.503	43.211
0.91	32.70	34.90	34.50	43.934	43.743	43.503
0.92	32.10	32.70	34.90	44.075	43.934	43.743
0.93	31.50	32.10	32.70	44.169	44.075	43.934
0.94	30.50	31.50	32.10	44.216	44.169	44.075

TABLE A5—BESSEL FILTER EXAMPLE (CONTINUED)

Time	X_i	X_{i-1}	X_{i-2}	Y_i	Y_{i-1}	Y_{i-2}
0.95	30.70	30.50	31.50	44.220	44.216	44.169
0.96	30.20	30.70	30.50	44.184	44.220	44.216
0.97	29.30	30.20	30.70	44.110	44.184	44.220
0.98	26.90	29.30	30.20	43.999	44.110	44.184
0.99	25.80	26.90	29.30	43.848	43.999	44.110
1.00	25.30	25.80	26.90	43.660	43.848	43.999

APPENDIX B

CORRECTIONS FOR AMBIENT TEST CONDITIONS

B.1 Introduction—Adjustment of snap-acceleration smoke values for the influence of ambient measurement conditions is an important and integral part of the SAE J1667 smoke measurement procedure. Testing has shown at-site ambient environmental conditions to be among the most influential testing factors that affect as-measured snap-acceleration smoke results. The ambient environmental factors incurred at the point of measurement in the form of altitude, barometric pressure, air temperature, and humidity have been combined into the single parameter of dry air density in order to provide a means of accounting for the influence of these factors on snap-acceleration test results. This appendix details procedures and offers guidelines for performing this important adjustment to snap-acceleration smoke values.

As will be summarized in Section B.7, the adjustment equations provided in this appendix were derived from an extensive snap-acceleration smoke test program involving a wide variety of heavy-duty diesel powered vehicles. One of the main conclusions of this test program was that each of the engines powering the test vehicles displayed different degrees of sensitivity to changes in air density. These differences were likely due to the different combustion and smoke control technologies employed by these engines at the time of their manufacture.

The air density adjustment equations provided in this appendix reflect the best fit nominal sensitivity of the sample of engines/vehicles evaluated. Some engines were more sensitive, and some were less sensitive, to the air density changes than predicted by the adjustment equations. In light of this, applying the correction equations to specific engines/vehicles of unknown air density sensitivity, the adjustment equations can only be considered approximate. It is recommended that regulatory agencies adopting this procedure in enforcement programs make some allowance for the fact that the air density sensitivity of individual vehicles tested in the program will, in general, not be known precisely and may be different than indicated by the nominal adjustment.

B.1.1 Reference Conditions—To perform an air density adjustment to an observed smoke value, it is necessary to define a reference air density which is used as the basis for the adjustment. The reference dry air density which was selected is:

$$1.1567 \text{ kg/m}^3 (0.0722 \text{ lbm/ft}^3)$$

This dry air density is the reference density specified in SAE J1349 and J1995, which specify the net and gross power rating conditions for diesel engines.

B.1.2 Precautions

- a. The air density extremes encountered during the smoke test program (see Section B.7) used to derive the adjustment equations ranged from a low of 0.908 kg/m^3 (0.0567 lbm/ft^3) to a high of 1.235 kg/m^3 (0.0771 lbm/ft^3). The adjustment equations provided in this appendix should not be used outside of this range of air density.
- b. The results from the study used to develop these correction factors suggested that at high temperatures above $32 \text{ }^\circ\text{C}$ ($90 \text{ }^\circ\text{F}$) and at low altitude sites around 412 m (1350 ft) in elevation there appeared to be a systematic temperature effect present that may not be accounted for by these correction factors. Residuals (the difference between measured values and calculated values) at these sites tend to decrease in value with increasing temperature. This may suggest the need for further adjustments to the equations to account for these temperature trends.
- c. The air density adjustment equations presented here were developed specifically for use with snap-acceleration smoke values obtained using the procedures, equipment, and analysis techniques described in this document. The adjustment equations are not recommended for use with snap-acceleration smoke values obtained using peak-reading type smokemeters, or other smoke measurement procedures.

B.2 Symbols

A	=	Final avg. snap-acceleration test result, in units of opacity (%) or smoke density $K(m^{-1})$, from Equation A4. "A" is equivalent to N_t or K_t , depending on the smoke units being used.
BARO	=	Barometric pressure, absolute, kPa (in-Hg).
c	=	Regression coefficient for ambient condition adjustment equation.
DBT	=	Dry bulb temperature, ambient temperature measured in conjunction with WBT, °C (°F).
DPT	=	Dew point temperature, °C (°F).
F	=	Ferrel's equation, saturation pressure adjustment factor.
K	=	Smoke density (extinction coefficient), per meter (m^{-1}).
N	=	Smoke opacity, in percent (%).
r	=	Air density (dry), kg/m^3 (lbm/ft ³).
Dr	=	Dry air density differential between actual test conditions or reference conditions, and base conditions.
RH	=	Relative humidity, percent (%).
SPT	=	Water saturation pressure at the ambient temperature, kPa (in-Hg).
SPWBT	=	Water saturation pressure at the wet bulb temperature, kPa (in-Hg).
T	=	Ambient temperature, if different from the DBT, °C (°F).
WBT	=	Wet bulb temperature, °C (°F).
WVP	=	Water vapor pressure, kPa (in-Hg).

NOTE—Pressure units given in in-Hg are referenced to 0 °C.

subscripts

abs	=	absolute temperature. $T + 273.15$ Kelvin ($T + 459.67$ °R)
base	=	base dry air density. The air density upon which the ambient conditions correction regression coefficients are based.
ref	=	at reference dry air density conditions, 1.1567 kg/m^3 (0.0722 lbm/ft ³).
t	=	at non-reference dry air density, usually actual test dry air density.

B.3 Snap-Acceleration Smoke Adjustment Methods—This appendix contains snap-acceleration adjustment equations that account for the air density effects on snap-acceleration smoke. The measured vehicle smoke value (A) is adjusted to the reference air density (ρ_{ref}). The measured smoke value (A), along with the actual dry air density (ρ_t) at the time of the test, are used in Section B.4 for opacity units or Section B.5 for smoke density units to compute the smoke level (N_{ref} or K_{ref}) at the reference air density (ρ_{ref}).

B.4 Adjustment of Snap-Acceleration Smoke Opacity (N) Values for the Effects of Changes in the Dry Air Density—The approach for adjusting smoke opacity values for the effects of changes in the dry air density is to convert the smoke opacity value, N_t , to smoke density units (K), adjust the smoke density value according to the procedures described in Section B.5, and then re-convert the adjusted smoke density value back into smoke opacity units as N_{ref} .

To adjust a snap-acceleration smoke opacity value for the effects of changes in the dry air density:

- a. Convert the smoke opacity value to the equivalent smoke density units using the following equation:

$$K = (-1/L) * \ln(1 - (N/100)) \quad (\text{Eq. B1})$$

where:

- | | | |
|---|---|--|
| K | = | Smoke density (m^{-1}). |
| L | = | Optical path length of the smoke measurement, in meters (m). If L is not known, assume a value of 0.127 m. |
| N | = | Smoke opacity value to be converted, usually N_t . |
- b. Adjust the resulting smoke density value, calculated in step 1, according to the procedures described in Section B.5 to produce K_{ref} .

- c. Convert the resulting adjusted smoke density value calculated in Section B.5 to equivalent smoke opacity units according to the following equation:

$$N = (1 - e^{-KL}) * 100 \quad (\text{Eq. B2})$$

where:

- N = Ambient conditions adjusted smoke opacity value, N_{ref} .
 K = Ambient conditions adjusted smoke density value, K_{ref} , determined in Section B.5.
 L = Optical path length value used in Equation B1.

NOTE—It is important to use the same value of L (optical path length) for the conversion to smoke density units and for the re-conversion back to smoke opacity units. The actual value of L is not critical; however, it must be a positive non-zero value.

B.5 Adjustment of Snap-Acceleration Smoke Density (K) Values for the Effects of Changes in the Dry Air Density—The base air density (ρ_{base}) parameter used in this section should not be confused with the reference air density (ρ_{ref}). The base air density is the ambient condition used to develop the adjustment regression coefficient used in this section. The adjustment equations in this section provide for the reference air density to be different from the base air density used in the regression analysis of the ambient conditions test data.

To adjust a measured snap-acceleration smoke density value to reference air density conditions:

- a. Calculate the air density differences using ρ_{ref} and ρ_{base} :

$$\Delta\rho_1 = \rho_{\text{ref}} - \rho_{\text{base}} \quad (\text{Eq. B3})$$

$$\Delta\rho_2 = \rho_t - \rho_{\text{base}} \quad (\text{Eq. B4})$$

- b. Calculate the adjusted snap-acceleration smoke density value, K_{ref} , at the reference dry air density, using Equation B5, and the appropriate values for coefficient c and r from Table B1.

$$K_{\text{ref}} = K_t * \frac{(c * \Delta\rho_1^2 + 1)}{(c * \Delta\rho_2^2 + 1)} \quad (\text{Eq. B5})$$

TABLE B1—SMOKE DENSITY ADJUSTMENT CONSTANTS

Air Density Units	c	ρ_{base}
kg/m ³	21.1234	1.2094 (metric)
lbm/ft ³	5420.0671	0.0755 (English)

- c. Substituting the values in Table B1 for c and ρ into Equation B3 through B5 produces Equation B6 and B7 for K_{ref} .

Metric Units ρ (kg/m³)

$$K_{\text{ref}} = \frac{K_t}{19.952 \rho_t^2 - 48.259 \rho_t + 30.126} \quad (\text{Eq. B6})$$

English Units ρ (lbm/ft³)

$$K_{\text{ref}} = \frac{K_t}{5119.55 \rho_t^2 - 773.05 \rho_t + 30.126} \quad (\text{Eq. B7})$$

B.6 Calculation of Dry Air Density—In order to correct the smoke values using the equations in Sections B.4 or B.5, it is first necessary to determine the dry air density at the test conditions. This can be done by measuring the barometric pressure (BARO), the ambient air temperature (T or DBT), and either the dew point temperature (DPT), or the wet and dry bulb temperatures (WBT and DBT), or the relative humidity (RH). From these measurements the dry air density may be determined from the following equation.

$$\rho = (u^*(\text{BARO} - \text{WVP})) / (T_{\text{abs}}) \quad (\text{Eq. B8})$$

where:

TABLE B2—

	Metric	English
ρ , Air Density (dry)	kg/m ³	lbm/ft ³
Units conversion (u)	3.4836	1.3255
Barometric Pressure (BARO)	kPa	in-Hg
Water Vapor Pressure (WVP)	kPa	in-Hg
Ambient Temperature (T _{abs})	Kelvin	°R

The barometric pressure and the ambient temperature must be measured at the test conditions of interest. The water vapor pressure may be calculated as described in B.6.1, or obtained from a psychrometric chart.

NOTE—Exclusion of the water vapor pressure term in Equation B8 (calculation of dry air density) is permissible, thus eliminating the need to measure DPT, WBT, or RH and calculate the WVP. However, the user should be aware that this results in a bias error, usually towards a smaller adjustment factor applied to the smoke values. In addition, it should be noted that as the ambient temperature increases, the amount of water the air can hold increases rapidly, and thus, the potential impact of this error also increases. The examples in Section B.6 illustrate the impact of ignoring the water vapor pressure in the adjustment equations.

B.6.1 Calculation of Water Vapor Pressure (WVP)—The method of calculating the water vapor pressure is dependent upon the instrumentation used to determine the moisture in the ambient air. The most common methods utilized are by the measurement of the dew point temperature (DPT), the measurement of the wet bulb/dry bulb temperatures, and by the measurement of the relative humidity (RH). From these measurements, the vapor pressure of the air may be determined.

B.6.1.1 CALCULATION OF WVP FROM DEW POINT TEMPERATURE—This procedure uses a dimensionless (normalized) polynomial for the vapor pressure calculation. This allows calculations to be performed in any units, utilizing the same polynomial coefficients. In using this technique, the input and output parameters to the polynomial are normalized and un-normalized, respectively, with the supplied support equations.

- a. Calculate the normalized dew point temperature (NT) from the measured dew point temperature (DPT).

$$\text{NT} = (\text{DPT} - \text{TL}) / (\text{TH} - \text{TL}) \quad (\text{Eq. B9})$$

TABLE B3—

Temperature Units	TL	TH
°C	-30.0	+40.0
°F	-22.0	+104.0

NOTE—DPT, TL, and TH must be in the same temperature units. Equation B9 applies over a dew point temperature range of -30 to +40 °C (-22 to +104 °F).

- b. Calculate the normalized water vapor pressure (NP) at the normalized dew point temperature (NT).

$$\begin{aligned} NP = & -4.959658E-5 + (4.956773E-2 * NT) & \text{(Eq. B10)} \\ & + (9.455172E-2 * NT^2) + (4.199096E-1 * NT^3) \\ & + (-7.549164E-2 * NT^4) + (5.114628E-1 * NT^5) \end{aligned}$$

- c. Un-normalize the saturation pressure (NP) to produce the WVP at the dew point temperature, DPT, in the units of choice.

$$WVP = PL + (NP * (PH - PL)) \quad \text{(Eq. B11)}$$

TABLE B4—

Pressure Units	PL	PH
kPa	5.0951E-2	7.375
in-Hg	1.5046E-2	2.178

NOTE—WVP, PL, and PH must be in the same pressure units.

B.6.1.2 CALCULATION OF WVP FROM WET BULB/DRY BULB TEMPERATURES—This procedure uses a dimensionless (normalized) polynomial for the vapor pressure calculation. This allows calculations to be performed in any units, utilizing the same polynomial coefficients. In using this technique, the input and output parameters to the polynomial are normalized and un-normalized, respectively, with the supplied support equations.

- a. Calculate the normalized wet bulb temperature (NT) from the measured wet bulb temperature (WBT).

$$NT = (WBT - TL) / (TH - TL) \quad \text{(Eq. B12)}$$

TABLE B5—

Temperature Units	TL	TH
°C	-30.0	+40.0
°F	-22.0	+104.0

NOTE—WBT, TL, and TH must be in the same temperature units. Equation B12 applies over a wet bulb temperature range of -30 to +40 °C (-22 to +104 °F).

- b. Calculate the normalized saturation pressure (NP) at the normalized wet bulb temperature (NT).

$$\begin{aligned} NP = & -4.959658E-5 + (4.956773E-2 * NT) & \text{(Eq. B13)} \\ & + (9.455172E-2 * NT^2) + (4.199096E-1 * NT^3) \\ & + (-7.549164E-2 * NT^4) + (5.114628E-1 * NT^5) \end{aligned}$$

SAE J1667 Issued FEB96

- c. Un-normalize the saturation pressure (NP) to produce the saturation pressure at the wet bulb temperature, SPWBT, in the units of choice.

$$SPWBT = PL + (NP*(PH - PL)) \quad (\text{Eq. B14})$$

TABLE B6—

Pressure Units	PL	PH
kPa	5.0951E-2	7.375
in-Hg	1.5046E-2	2.178

NOTE—SPWBT, PL, and PH must be in the same pressure units.

- d. Using Ferrel's equation, calculate the adjustment factor (F).
Metric Units—WBT in °C

$$F = 3.67E-4*(1 + (1.152E-3*WBT)) \quad (\text{Eq. B15})$$

English Units—WBT in °F

$$F = 3.67E-4*(1 + (6.4E-4*(WBT - 32))) \quad (\text{Eq. B16})$$

- e. Calculate the Water Vapor Pressure (WVP).

Metric Units—SPWBT, BARO in kPa; DBT, WBT in °C.

$$WVP = SPWBT - (1.8*F*BARO*(DBT - WBT)) \quad (\text{Eq. B17})$$

English Units—SPWB, BARO in in-Hg; DBT, WBT in °F.

$$WVP = SPWBT - (F*BARO*(DBT - WBT)) \quad (\text{Eq. B18})$$

B.6.1.3 CALCULATION OF WVP FROM RELATIVE HUMIDITY AND AMBIENT TEMPERATURE—This procedure uses a dimensionless (normalized) polynomial for the vapor pressure calculation. This allows calculations to be performed in any units, utilizing the same polynomial coefficients. In using this technique, the input and output parameters to the polynomial are normalized and un-normalized, respectively, with the supplied support equations.

- a. Calculate the normalized ambient temperature (NT) from the measured ambient temperature (T).

$$NT = (T - TL)/(TH - TL) \quad (\text{Eq. B19})$$

TABLE B7—

Temperature Units	TL	TH
°C	-30.0	+40.0
°F	-22.0	+104.0

NOTE—T, TL, and TH must be in the same temperature units. Equation B19 applies over an ambient temperature range of -30 to +40 °C (-22 to +104 °F).

SAE J1667 Issued FEB96

- b. Calculate the normalized saturation pressure (NP) at the normalized ambient temperature (NT).

$$NP = -4.959658E-5 + (4.956673E-2*NT) + (9.455172E-2*NT^2) + (4.199096E-1*NT^3) + (-7.549164E-2*NT^4) + (5.114628E-1*NT^5) \quad (\text{Eq. B20})$$

- c. Un-normalize the saturation pressure (NP) to produce the saturation pressure at the ambient temperature, SPT, in the units of choice.

$$SPT = PL + (NP*(PH - PL)) \quad (\text{Eq. B21})$$

TABLE B8—

Pressure Units	PL	PH
kPa	5.0951E-2	7.375
in-Hg	1.5046E-2	2.178

NOTE—SPT, PL, and PH must be in the same pressure units.

- d. Calculate the WVP at the measured relative humidity, RH. WVP will be in the same units as SPT.

$$WVP = SPT*(RH/100) \quad (\text{Eq. B22})$$

B.7 Examples of Adjustments to Ambient Smoke Values—The following hypothetical examples may assist in applying the ambient correction equations. Both metric and English unit based examples are provided. Also included for reference are the applicable equation numbers used in this appendix.

Example 1

Situation—A vehicle tested for smoke at a moderate elevation produces an average snap-acceleration smoke value of 60% opacity (the (A) value reported from Equation B3).

Task—From the ambient conditions measurements, determine the adjusted smoke opacity (N_{ref}) at the reference air density (ρ_{ref}).

Ambient measurements	Equation Constants
Smoke (A)= 60% opacity	c = 54.200671
(BARO)= 27.00 in-Hg	TL = -22 x °F
(T)= 77 x °F	TH = 104 x °F
(RH)= 50%	PL = 1.5046E-2 in-Hg
	PH = 2.178 in-Hg
	EOPL = 0.127 m
	(ρ_{ref}) = 0.0722 lbm/ft ³
	(ρ_{base}) = 0.0755 lbm/ft ³

Calculations:

$$\begin{aligned}
 (\text{Eq.B19}) \quad NT &= (77 - (-22))/(104 - (-22)) = 0.785714 \\
 (\text{Eq.B20}) \quad NP &= 0.425334 \text{ (polynomial)} \\
 (\text{Eq.B21}) \quad \text{SPT} &= 1.5046\text{E-}2 + 0.425334 * (2.178 - 1.5046\text{E-}2) \\
 &= 0.935024 \\
 (\text{Eq.B22}) \quad \text{WVP} &= 0.935024 * (50.0/100) \\
 &= 0.4675 \\
 (\text{Eq.B8}) \quad \rho_{\text{dry}} &= (1.3255 * (27.0 - 0.4675))/(77 + 459.67) \\
 &= 0.06553 \\
 (\text{Eq.B1}) \quad K_t &= 7.215 \\
 (\text{Eq.B3}) \quad \Delta \rho_1 &= 0.0722 - 0.0755 = -0.0033 \\
 (\text{Eq.B4}) \quad \Delta \rho_2 &= 0.06553 - 0.0755 = -0.00996 \\
 (\text{Eq.B5}) \quad K_{\text{ref}} &= 4.966 \\
 (\text{Eq.B2}) \quad N_{\text{ref}} &= 46.8\%
 \end{aligned}$$

Result—A vehicle with a snap-acceleration smoke level of 60% opacity at a dry air density of 0.0655 lbm/ft³ would be projected to produce a smoke value of 46.8% opacity at the reference dry air density of 0.0722 lbm/ft³.

It should be noted that if the RH measurement had not been performed and the effect of WVP ignored, the resulting impact would have changed N_{ref} from 46.8% to 49.5% opacity.

Example 2

Situation—A vehicle tested for smoke at a moderate elevation produces an average snap-acceleration smoke density of 7.2 m⁻¹ (the (A) value reported from Equation B3).

Task—From the ambient conditions measurements, determine the adjusted smoke density (K^{ref}) at the reference air density (ρ_{ref}).

Ambient measurements		Equation Constants	
Smoke (A)	= 7.2 m ⁻¹	c	= 0.211234
(BARO)	= 88.50 kPa	TL	= -30 °C
(T)	= 20 °C	TH	= 40 °C
(DPT)	= 10 °C	PL	= 5.0951E-2 kPa
		PH	= 7.375 kPa
		(ρ_{ref})	= 1.1567 kg/m ³
		(ρ_{base})	= 1.2094 kg/m ³

Calculations:

$$\begin{aligned}
 (\text{Eq.B9}) \quad NT &= (10 - (-30))/(40 - (-30)) = 0.571428 \\
 (\text{Eq.B10}) \quad NP &= 0.160612 \text{ (polynomial)} \\
 (\text{Eq.B11}) \quad \text{WVP} &= 5.0951\text{E-}2 - (0.160612 * (7.375 - 5.0951\text{E-}2)) \\
 &= 1.2272 \\
 (\text{Eq.B8}) \quad \rho_{\text{dry}} &= (3.4836 * (88.5 - 1.227))/(20 + 273.15) \\
 &= 1.0370 \\
 (\text{Eq.B3}) \quad \Delta \rho_1 &= 1.1567 - 1.2094 = -0.0527 \\
 (\text{Eq.B4}) \quad \Delta \rho_2 &= 1.0370 - 1.2094 = -0.17230 \\
 (\text{Eq.B5}) \quad K_{\text{ref}} &= 4.684 \text{ m}^{-1}
 \end{aligned}$$

Result—A vehicle with a snap-acceleration smoke density of 7.2 m⁻¹ at a dry air density of 1.0370 kg/m³ would be projected to produce a smoke density of 4.684 (m⁻¹) at the reference dry air density of 1.1567 kg/m³.

B.8 Snap-Acceleration/Air Density Field Test Program—The snap-acceleration smoke adjustment equations of this appendix were derived using data from a smoke test program designed to study the effects of ambient conditions on snap-acceleration smoke levels. The test program was conducted during the summer of 1993 and involved measuring the snap-acceleration levels of several heavy-duty diesel-powered vehicles, as the vehicles traveled an out and back route over a wide range of elevations on Interstate 80, in California. The vehicles were tested for snap-acceleration smoke with several types of smokemeters using the SAE J1667 test procedures and data analysis algorithm. Eight tests were performed at six different elevations along the route. At two of the elevations, tests were performed on both the outbound and return legs of the test route. The range of the ambient test conditions encountered during the test program are shown in Table B9.

TABLE B9—TEST PROGRAM AMBIENT EXTREMES

Units	min	max
Metric		
Elevation	12 m	2207 m
Air Density (dry)	0.906 kg/m ³	1.235 kg/m ³
Air Density (wet)	0.915 kg/m ³	1.240 kg/m ³
Barometer	78.3 kPa	101.7 kPa
Ambient Temp.	11.7 °C	37.2 °C
Specific Humidity	0.6 gm/kg	12.7 gm/kg
English		
Elevation	40 ft	7240 ft
Air Density (dry)	0.0567 lbm/ft ³	0.0771 lbm/ft ³
Air Density (wet)	0.0571 lbm/ft ³	0.0774 lbm/ft ³
Barometer	23.11 in-Hg	30.03 in-Hg
Ambient Temp.	53 °F	99 °F
Specific Humidity	4 grains	89 grains

A total of 24 diesel-powered vehicles were tested in the program, with the number, type, and manufacturer of the diesel engines powering these vehicles providing a fairly representative sample of the engines in the general U.S. heavy-duty vehicle population. Engines manufactured by Caterpillar, Cummins, Detroit Diesel (both 2 and 4 cycle), and Mack were included in the test sample, as were engines with both mechanical and electronic injection control systems. There was one naturally aspirated engine in the test sample with the rest being turbocharged. The manufacturing dates of the engines covered a range from 1971 to 1993 with about 46% of the engines manufactured in the 1985-1989 period and about 33% manufactured between 1990 and 1993.

Four different manufacturers of smokemeters (Bosch, Caltest, Sun, and Wager) participated in the test program. The smokemeters included full flow end-of-line (EOL) and sampling type smokemeters. Both peak-reading meters and prototype meters which were programmed to perform the SAE J1667 half-second averaging algorithm were included in the testing.

The data from the testing program were assembled into a single data base so that standard mathematical and statistical procedures could be utilized to query for relationships among the various test parameters. Data from the peak-reading meters and data which did not meet the SAE J1667 test validation criteria, as given in 5.4.4, were excluded from the analyses. Dry air density, barometric pressure, and altitude all produced significant correlations with the snap-acceleration smoke values, with dry air density providing the better correlation.

SAE J1667 Issued FEB96

The data from this test program were also used to quantify the repeatability of the test procedure. This was done in two ways. In the first method, the average of the ambient condition corrected smoke values was computed for each vehicle, test day and smokemeter combination. The deviations of the individual corrected smoke values from this average were then computed and used to provide a measure of the repeatability of the test procedure over the full range of ambient conditions encountered in the test program and allowed by the procedure. When this was done for all the data in the test program data base, 91% of the deviations from average were less than 6% opacity.

In the second method, only the data taken at the two elevations where repeat tests were run were utilized. For each vehicle/meter combination the two test results obtained at these test locations created a data pair which differed only slightly in ambient dry air density. (Since the elevation was the same for both points in the data pair, the only source of air density differences was the change in ambient conditions which occurred in the few hours between the two tests.) All these smoke values were corrected to the standard reference air density using the methods described in this appendix and the deviation of the corrected smoke values was noted for each data pair. For 90% of the pairs, the deviations were less than 3% opacity.

The difference in the repeatabilities quantified by the two methods reflects the imprecision of applying the ambient condition corrections to specific vehicles over wide ranges of air density.

APPENDIX C

APPLICATION OF CORRECTIONS TO MEASURED SMOKE VALUES

C.1 Introduction—Fundamentally, all smoke opacimeters measure the transmittance of light through a smoke plume or a sample of gas which contains smoke particles. Typically, however, it is desired to quantify and report the exhaust smoke emissions in units of either smoke opacity (N) or smoke density (k). Furthermore, if the smoke level is reported as smoke opacity, then is it also necessary to report the associated effective optical path length to fully specify the smoke level of the vehicle. This is because measured smoke opacity is a function of the effective optical path length (EOPL) used to make the measurement. For example, an engine that yielded a 20% opacity when tested with a tailpipe which caused the EOPL to be 76 mm would have measured opacities of 26%, 31%, and 36%, respectively, when tested with larger tailpipes which caused the EOPL to be 102, 127, and 152 mm. Therefore, to facilitate comparisons of smoke opacity data from different sources and with smoke standards which may be developed, opacity values must be reported at standard effective optical path lengths.

When smoke is measured using an effective optical path length which is different than the standard path length, the measured smoke values must be converted to opacity at the standard path length using the appropriate Beer-Lambert relationship. Similarly, if it is desired to report the test results in units of smoke density, it is necessary to use the Beer-Lambert relationship to convert the measured opacity results to smoke density.

Finally, if smoke measurements are made using a smokemeter having a red LED light source, a wavelength correction is necessary to account for the fact that the ability of diesel smoke to absorb light depends on the wavelength of the light.

This appendix describes how measured smoke values are to be corrected to the desired reporting units using the Beer-Lambert relationships and how the light source wavelength corrections are to be made.

C.2 Definitions and Symbols

C.2.1 Diesel Smoke—Particles, including aerosols, suspended in the exhaust stream of a diesel engine which absorb, reflect, or refract light.

C.2.2 Transmittance (T)—The fraction of light transmitted from a source which reaches a light detector.

C.2.3 Opacity (N)—The percentage of light transmitted from a source which is prevented from reaching a light detector.

C.2.4 Effective Optical Path Length (L)—The length of the smoke obscured optical path between the smokemeter light source and light detector. Note that portions of the total light source to detector path length which are not smoke obscured do not contribute to the effective optical path length.

C.2.5 Smoke Density (k)—A fundamental means of quantifying the ability of a smoke plume or a smoke-containing gas sample to prevent the passage of light. By convention, smoke density is expressed on a per meter basis (m^{-1}).

C.2.6 W—The wavelength of the smokemeter light source.

C.2.7 Subscripts

C.2.7.1 m—Refers to the as-measured condition

C.2.7.2 s—Refers to values corrected to a standard condition

C.3 Beer-Lambert Relationships—The Beer-Lambert Law defines the relationship between transmittance, smoke density, and effective optical path length as shown in Equation C1.

$$T = e^{-kL} \quad (\text{Eq. C1})$$

From the definitions of transmittance and opacity, the relationship between these parameters may be defined as shown in Equation C2.

$$N(\%) = 100*(1 - T) \quad (\text{Eq. C2})$$

From Equations C1 and C2 the following important relationships can be derived:

$$N_s = 100*(1 - ((1 - (N_m/100))(L_s/L_m))) \quad (\text{Eq. C3})$$

$$k = -(1/L_m)*(1n(1 - (N_m/100))) \quad (\text{Eq. C4})$$

To achieve proper results in applying Equations C1 and C4, the effective optical path lengths (L and L_m) must be expressed in units of meters (m). It is recommended that the effective optical path lengths used in Equation C3 also be expressed in meters (m); however, any length unit may be used as long as L_s and L_m are expressed in the same measurement unit.

C.4 Use of Beer-Lambert Relationships—Conversion from as-measured smoke values to appropriate reporting units is a two-step process. Since, as noted in Section C.1, the basic measurement unit of all smokemeters is transmittance, the first step in all cases is to convert from transmittance (T) to opacity at the as-measured effective optical path length (N_m) using Equation C2. Since all opacimeters do this internally, this step is transparent to the user.

The second step of the process is to convert from N_m to the desired reporting units as follows:

- a. If the test results are to be reported in opacity units, Equation C3 must be used to convert from opacity at the as-measured effective optical path length to opacity at the standard effective optical path length. (In the event that the measured and standard effective optical path lengths are identical, N_s is equal to N_m and this secondary conversion step is not required.)
- b. If the test results are to be reported in units of smoke density, then Equation C4 must be applied.

C.5 Effective Optical Path Length Input Values—In order to apply conversion Equation C4, it is necessary to input the as-measured effective optical path length (L_m). To use Equation C3, values must be input both for L_m and for L_s , the standard effective optical path length. This section provides guidance on the determination of these input values.

C.5.1 Determination of L_m —For full-flow end-of-line type smokemeters, L_m is a function of the vehicle tailpipe design. For straight tailpipes with a circular cross section, L_m is equal to the tailpipe ID. For tailpipes constructed of common tubing, the tubing OD may be used to approximate the tubing ID. Appendix D provides guidance in determining L_m for other tailpipe configurations.

For sampling type smokemeters, L_m is a fixed function of the meter measurement cell and purge air system design. Specification data supplied by the meter manufacturer should be consulted to determine the appropriate value for L_m when this type of smokemeter is used.

Typically, it is necessary to determine L_m within ± 5 mm to achieve corrected smoke results that are accurate within $\pm 2\%$ opacity or $\pm 0.2 \text{ m}^{-1}$ smoke density.

C.5.2 Determination of L_s —To ensure meaningful smoke data comparisons, smoke opacity results should be reported at the standard effective optical path lengths, L_s shown in Table C1. Table C1 is constructed such that the standard effective optical path length increases with the engine power rating and approximates exhaust tailpipe sizes commonly used in vehicle applications. In cases where the engine rated power cannot be determined, the actual tailpipe OD usually provides a good approximation of L_s and may be used in lieu of Table C1.

TABLE C1—STANDARD EFFECTIVE OPTICAL PATH LENGTHS

Related Engine Power kW	Rated Engine Power BHP	Standard Effective Optical Path length mm	Standard Effective Optical Path Length in
Less than 75	Less than 101	51	2
75 to 149	101 to 200	76	3
150 to 224	201 to 300	102	4
225 or More	301 or more	127	5

When testing vehicles with multiple exhaust outlets, the total rated engine power must be used with Table C1 to determine the standard effective optical path length. The rated engine power must not be divided by the number of exhaust outlets when using Table C1. If this error is made, it will result in reported smoke opacity values which are erroneously low.

C.6 Sequencing of Beer-Lambert Corrections

C.6.1 Preferred Method—To achieve the highest degree of accuracy, the Beer-Lambert conversion calculations described in Section C.4 should be performed on each instantaneous measured smoke value before any further data-processing takes place. To perform the calculations in this manner during snap-acceleration testing requires significant data-processing capacity since the minimum smoke data-processing rate is 20 Hz. In addition, the ability to input values for L_m and L_s to the data-processing unit is required.

C.6.2 Alternate Methods—In some cases, users may wish to use data-processing systems which are not capable of performing the Beer-Lambert corrections using the preferred method in C.6.1. In these cases, either of the following alternate techniques may be employed; however, users are cautioned that there will be some loss of accuracy.

- a. The appropriate Beer-Lambert conversion equations as defined in Section C.4 may be applied after instantaneous smoke values have been averaged using the procedures described in Appendix A. The snap-acceleration test error that results from the use of this method will, in most cases, be less than 1% opacity or 0.15 m^{-1} smoke density, but could be somewhat higher when the snap-acceleration test generates a very high and sharp smoke spike.
- b. Appropriate Beer-Lambert conversions may be performed manually on as-measured average smoke values by using the alignment chart shown in Figure C1. In this method, an as-measured smoke opacity (N_m) is located on the vertical column which most closely represents the as-measured effective optical path length (L_m). The user then reads horizontally across the chart to the column which represents the standard effective optical path length (L_s) if a smoke opacity output is desired, or to the smoke density column if a density output is desired. The user then reads the desired output by interpolating the scale of the target column. For example, if an opacity value of 40% were measured using an effective optical path length of 102 mm (4 in), the chart could be used to determine that the equivalent opacity at a path length of 127 mm (5 in) is approximately 47% and that the associated smoke density is about 5.0 m^{-1} .

Since the alignment chart was developed using Equations C3 and C4, the fundamental accuracy of this method is the same as alternate method (a). However, when the as-measured effective optical path length is not equal to one of the values which appear as one of the vertical chart scales the utility and/or accuracy of this method is reduced. This method also introduces the potential for small errors due to resolution and readability of the non-linear chart scales.

C.7 Smokemeter Light Source Wavelength Corrections—The ability of diesel smoke to absorb light is wavelength dependent (i.e., diesel smoke does not have neutral spectral density). For this reason, smokemeters using different light sources will respond differently to the same smoke sample, and corrections are required to achieve comparable results.

Since most smokemeters today use either a green LED or an incandescent light source, with an equivalent peak spectral emissivity, this will be the standard for reporting snap-acceleration test results. Smoke measurements made with meters using red LED light sources must be corrected using the following equations.

$$N_s = 100 * (1 - ((1 - (N_m / 100)) * (w_m / w_s))) \quad (\text{Eq. C5})$$

$$K_s = (-1/L) * 1n((1 - (N_m / 100)) * (w_m / w_s)) \quad (\text{Eq. C6})$$

where:

W_s = the wavelength of a standard green LED light source = 570 nm

W_m = the wavelength of a red LED light source = 660 nm

It is preferred that the wavelength corrections, like the Beer-Lambert corrections, be applied to each instantaneous measured smoke value. However, if this is not possible, and if small errors are acceptable, the wavelength corrections may be applied after average smoke values are obtained as described in Appendix A.

Light source wavelength corrections using Equations C5 and C6 should be applied when the meter is used to measure diesel smoke, but should not be used when the meter is being calibrated using a neutral density filter.

OPACITY, %					Density K 1/m	OPACITY, %					Density K 1/m
EXHAUST OUTLET DIAMETER						EXHAUST OUTLET DIAMETER					
2" 51mm	3" 76mm	4" 102mm	5" 127mm	6" 152mm		2" 51mm	3" 76mm	4" 102mm	5" 127mm	6" 152mm	
33	45	55	63	70		54	69	79			
32	44	54	62	69	7.50						15.00
31	43	53	61	68		53	68	78	85		
30	42	52	60	67	7.00						14.50
29	41	51	59	66		52	67	77	84	89	
28	40	50	58	65	6.50						14.00
27	39	49	57	64		51	66	76	83	88	
26	38	48	56	63	6.00						13.50
25	37	47	55	62		50	65	75	82	87	
24	36	46	54	61	5.50						13.00
23	35	45	53	60		49	64	74	81	86	
22	34	44	52	59	5.00						12.50
21	33	43	51	58		48	63	73	80	85	
20	32	42	50	57	4.50						12.00
19	31	41	49	56		47	62	72	79	84	
18	30	40	48	55	4.00						11.50
17	29	39	47	54		46	61	71	78	83	
16	28	38	46	53	3.50						11.00
15	27	37	45	52		45	60	70	77	82	
14	26	36	44	51	3.00						10.50
13	25	35	43	50		44	59	69	76	81	
12	24	34	42	49	2.50						10.00
11	23	33	41	48		43	58	68	75	80	
10	22	32	40	47	2.00						9.50
9	21	31	39	46		42	57	67	74	79	
8	20	30	38	45	1.50						9.00
7	19	29	37	44		41	56	66	73	78	
6	18	28	36	43	1.00						8.50
5	17	27	35	42		40	55	65	72	77	
4	16	26	34	41	0.50						8.00
3	15	25	33	40		39	54	64	71	76	
2	14	24	32	39		38	53	63	70	75	
1	13	23	31	38		37	52	62	69	74	
	12	22	30	37		36	51	61	68	73	
	11	21	29	36		35	50	60	67	72	
	10	20	28	35		34	49	59	66	71	
	9	19	27	34		33	48	58	65	70	
	8	18	26	33		32	47	57	64	69	
	7	17	25	32		31	46	56	63	68	
	6	16	24	31		30	45	55	62	67	
	5	15	23	30		29	44	54	61	66	
	4	14	22	29		28	43	53	60	65	
	3	13	21	28		27	42	52	59	64	
	2	12	20	27		26	41	51	58	63	
	1	11	19	26		25	40	50	57	62	
		10	18	25		24	39	49	56	61	
		9	17	24		23	38	48	55	60	
		8	16	23		22	37	47	54	59	
		7	15	22		21	36	46	53	58	
		6	14	21		20	35	45	52	57	
		5	13	20		19	34	44	51	56	
		4	12	19		18	33	43	50	55	
		3	11	18		17	32	42	49	54	
		2	10	17		16	31	41	48	53	
		1	9	16		15	30	40	47	52	
			8	15		14	29	39	46	51	
			7	14		13	28	38	45	50	
			6	13		12	27	37	44	49	
			5	12		11	26	36	43	48	
			4	11		10	25	35	42	47	
			3	10		9	24	34	41	46	
			2	9		8	23	33	40	45	
			1	8		7	22	32	39	44	
				7		6	21	31	38	43	
				6		5	20	30	37	42	
				5		4	19	29	36	41	
				4		3	18	28	35	40	
				3		2	17	27	34	39	
				2		1	16	26	33	38	
				1			15	25	32	37	
							14	24	31	36	
							13	23	30	35	
							12	22	29	34	
							11	21	28	33	
							10	20	27	32	
							9	19	26	31	
							8	18	25	30	
							7	17	24	29	
							6	16	23	28	
							5	15	22	27	
							4	14	21	26	
							3	13	20	25	
							2	12	19	24	
							1	11	18	23	
								10	17	22	
								9	16	21	
								8	15	20	
								7	14	19	
								6	13	18	
								5	12	17	
								4	11	16	
								3	10	15	
								2	9	14	
								1	8	13	
									7	12	
									6	11	
									5	10	
									4	9	
									3	8	
									2	7	
									1	6	

FIGURE C1—ALIGNMENT CHART

APPENDIX D

EXHAUST SYSTEMS AND SPECIAL APPLICATIONS

D.1 Introduction—In order to report snap-acceleration test results at standard conditions, the Beer-Lambert effective optical path length corrections described in Appendix C must be applied to the as-measured smoke values. A required input for the Beer-Lambert corrections is the as-measured effective optical path length (L_m). When a sampling type smokemeter is used, L_m is a function of the meter design and is expected to be supplied by the meter manufacturer. When a full-flow end-of-line smokemeter is used, L_m is a function of the vehicle exhaust system and the way the meter is mounted on the tailpipe. Users of full-flow smokemeters must, therefore, determine L_m for each test conducted on a case by case basis.

Recognizing the wide variety of exhaust systems that may be encountered when conducting vehicle tests, this appendix provides guidelines which will assist full-flow smokemeter users in determining L_m . This appendix also includes suggestions for mounting full-flow meters on specific types of vehicular exhaust systems. Following these suggestions will facilitate the determination of L_m and will insure that proper smoke measurement principles are adhered to.

D.2 Determination of the As-Measured Effective Optical Path Length (L_m)

D.2.1 General Comments—The effective optical path length has been defined as “the length of the smoke obscured path between the smokemeter light source and detector.” Portions of the light source to detector path length which are not smoke obscured do not contribute to the effective optical path length. If the smokemeter light beam is located sufficiently close to the exhaust outlet (within 7 cm or 2.76 in) the cross section of the smoke plume as it passes by the smokemeter is essentially the same as the tailpipe outlet and the effective optical path length is equal to the internal distance across the tailpipe outlet along the line of orientation of the smokemeter light beam. In general, this distance should be determined by direct measurement of the tailpipe outlet, and to achieve corrected smoke results which are within $\pm 2\%$ opacity or $\pm 0.2 \text{ m}^{-1}$ smoke density, this measurement should be made within $\pm 5 \text{ mm}$ ($\pm 0.197 \text{ in}$).

It is often difficult, particularly in roadside testing applications, to gain access to and obtain direct measurements of the tailpipe outlets on many vehicles. Fortunately, for many common tailpipe designs L_m can be determined with sufficient accuracy from external exhaust system dimensions which are more easily measured. The remainder of this section describes these cases and the principles and procedures that should be adhered to in determining L_m .

D.2.2 External Versus Internal Tailpipe Dimensions—Most tailpipes encountered on vehicles are constructed from metal tubing of various standard nominal sizes. Nominal tubing sizes are based on the tubing OD whereas it is the internal dimension of the tailpipe that dictates L_m . The difference between the external and internal tailpipe dimension is twice the tubing wall thickness which is typically about 1.5 mm (0.060 in).

Use of the external tailpipe dimension as the as-measured effective optical path length results in corrected smoke values which are slightly less than the true corrected smoke values ($\sim 1\%$ opacity or 0.01 m^{-1} smoke density). In most cases, this small error is acceptable. However, in cases where extreme accuracy is required or where the tailpipe wall thickness is unusually large, the material thickness should be accounted for in determining L_m .

D.2.3 Straight Circular Non-Beveled Tailpipes—This is the simplest tailpipe design that may be encountered and is illustrated in Figure D1. In this case, the smokemeter light beam should be oriented such that it is perpendicular to and passes through the central axis of the smoke plume and is within 70 mm (2.76 in) of the tailpipe exit. If these guidelines are followed, L_m is equal to the tailpipe ID and can usually be adequately approximated by the tailpipe OD (see D.2.2).

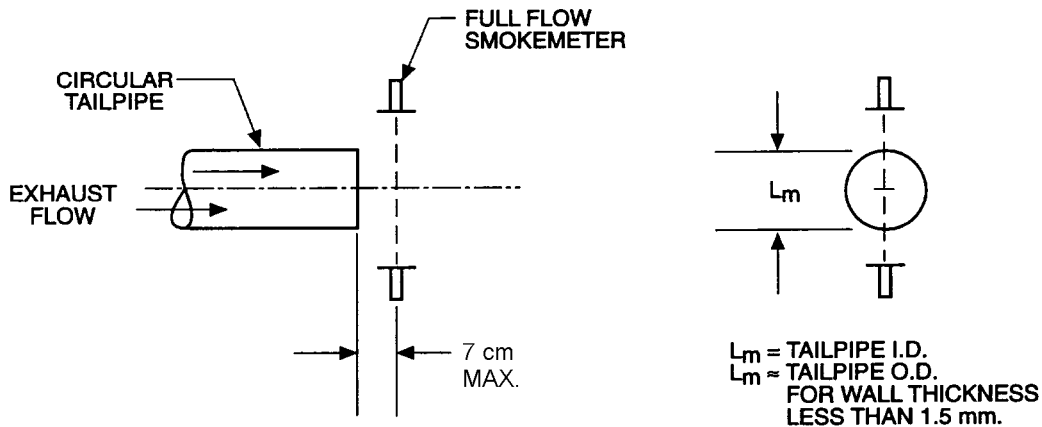

FIGURE D1—STRAIGHT CIRCULAR NON-BEVELED TAILPIPE

D.2.4 Straight Circular Beveled Tailpipes—A beveled tailpipe is formed when the outlet of the tailpipe is not cut off square (perpendicular) to the axis of the exhaust flow. When this type of tailpipe is encountered, there is only one recommended smokemeter mounting orientation. The axis of the smokemeter light beam should be perpendicular to and passing through the central axis of the smoke plume and should be parallel to the minor axis of the elliptical shape of the tailpipe exit. The smokemeter light beam must also be within 70 mm (2.76 in) of the tailpipe outlet (Figure D2). If these guidelines are followed, L_m is equal to the tailpipe ID and can usually be adequately approximated by the tailpipe OD (see D.2.2).

D.2.5 Curved Circular Tailpipes—When the central axis of the tailpipe is curved at the approach to the exit, the tailpipe is said to be curved and the cross section of the tailpipe outlet is non-circular. To avoid erroneously low readings when this type of tailpipe is encountered, the smokemeter should be mounted such that the axis of the smokemeter light beam is perpendicular to and passing through the central axis of the smoke plume (not necessarily the centerline of the pipe) and is parallel to the minor axis of the tailpipe exit. The smokemeter light beam must also be within 70 mm (2.76 in) of the tailpipe exit (Figure D3). If these guidelines are followed, L_m is equal to the tailpipe ID and can usually be adequately approximated by the tailpipe OD (see D.2.2).

Smokemeter orientations in which the smokemeter light beam is not parallel to the minor axis of the tailpipe exit may be used, but in these cases it will be necessary to determine L_m by direct measurement.

D.2.6 Non-Circular Tailpipe—If the tailpipe cross section is non-circular, the smokemeter should be mounted such that the smokemeter light beam is perpendicular to and passes through the central axis of the smoke plume and is within 70 mm (2.76 in) of the tailpipe exit. For these cases, L_m will need to be determined by direct measurement. If the tailpipe cross section is an oval or ellipse, it is recommended that the smokemeter light beam be aligned with either the major or minor axis of the tailpipe cross section in order to facilitate the measurement of L_m (Figure D4).

RECOMMENDED SMOKEMETER ORIENTATION

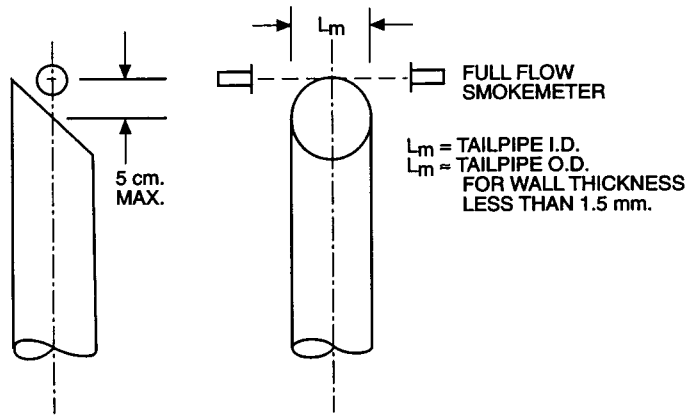

SMOKEMETER ORIENTATIONS WHICH ARE NOT RECOMMENDED

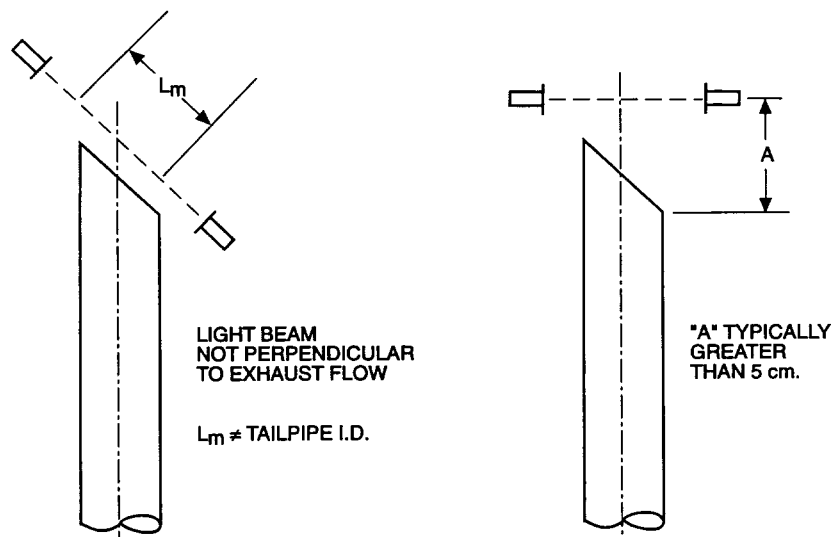
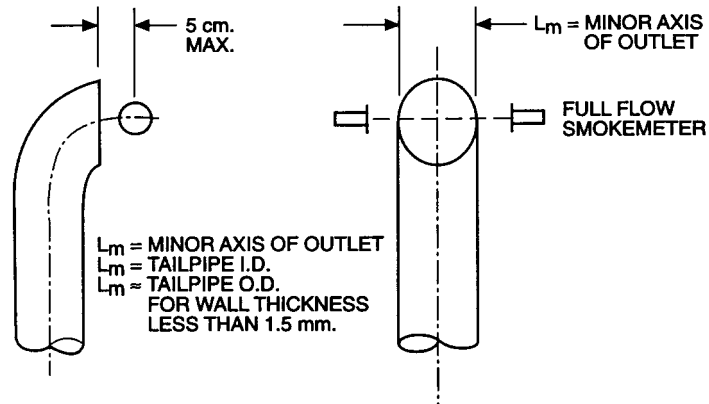

FIGURE D2—STRAIGHT CIRCULAR BEVELED TAILPIPE

RECOMMENDED SMOKEMETER ORIENTATION



ACCEPTABLE SMOKEMETER ORIENTATION

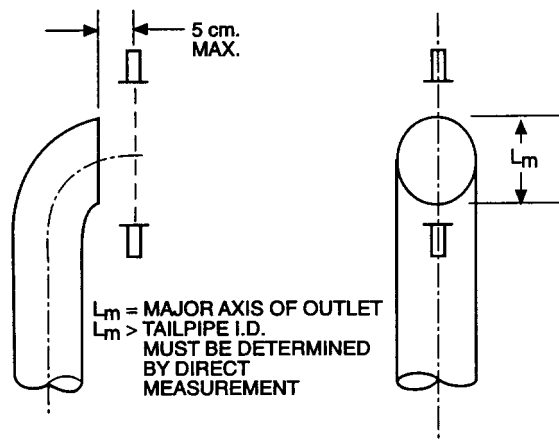
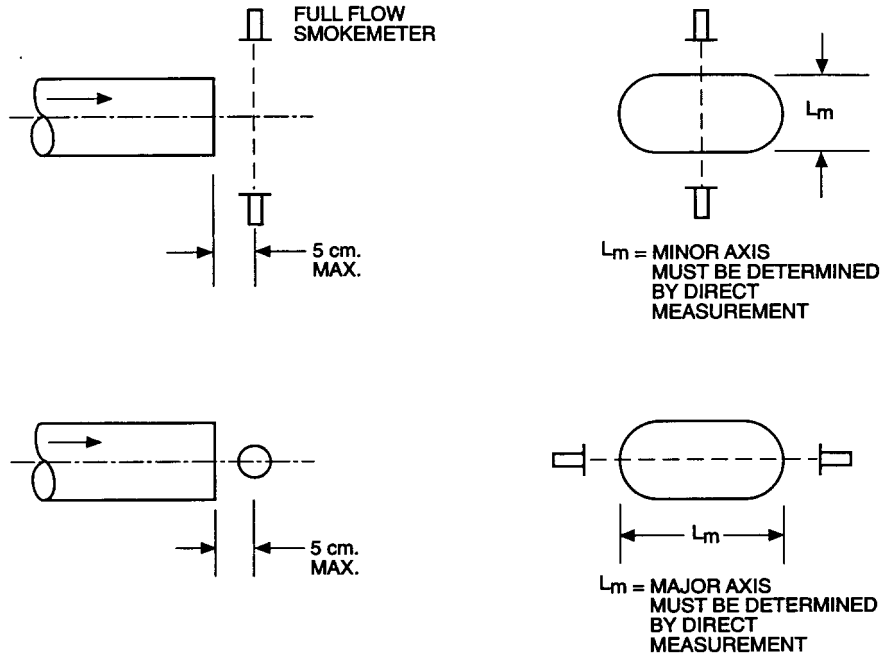

FIGURE D3—CURVED CIRCULAR TAILPIPE

RECOMMENDED SMOKEMETER ORIENTATIONS



SMOKEMETER ORIENTATION WHICH IS NOT RECOMMENDED

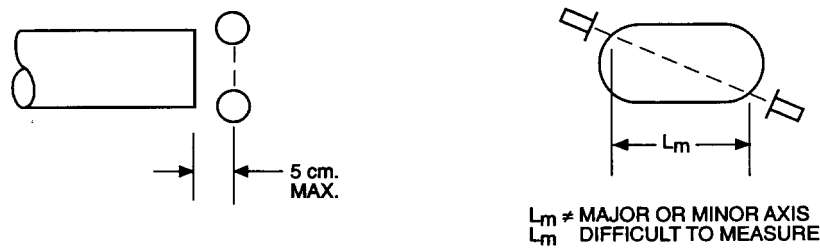

FIGURE D4—NON-CIRCULAR TAILPIPE

D.3 Other Conditions

D.3.1 Rain Caps—Smoke measurements cannot be performed using a full-flow end-of-line smokemeter when a tailpipe rain cap is operational. If present, rain caps must be removed or secured in the fully open position prior to smoke testing. If the smokemeter is installed without removing the rain cap, the meter must be oriented so that the cap does not interfere with the smoke plume or block any portion of the smokemeter light beam (Figure D5).

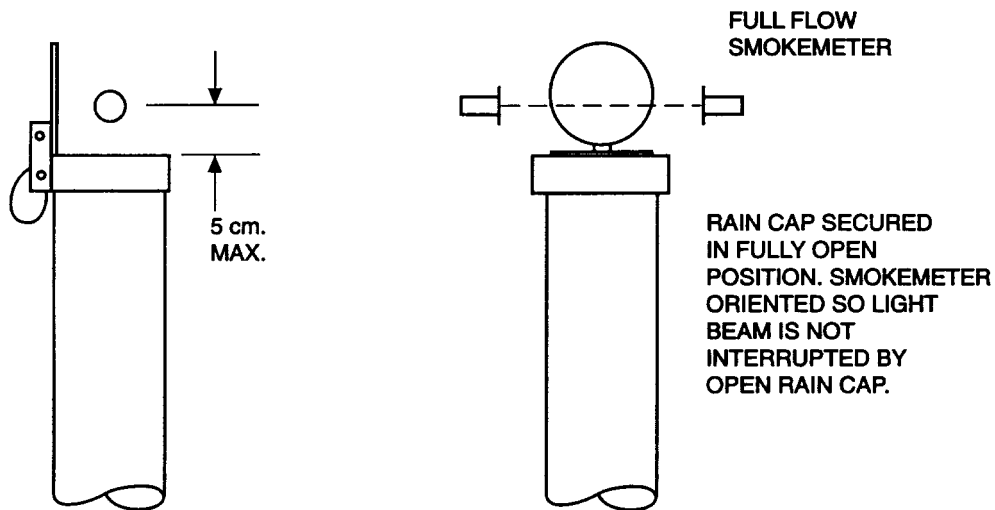

FIGURE D5—RAIN CAP

D.3.2 Downward Directed Exhaust—Many vehicles have horizontal exhaust systems affixed to the underside of the vehicle chassis. Typically these exhaust systems have a curved tailpipe which directs the exhaust flow down against the surface of the roadway.

Care should be exercised when using a full-flow end-of-line smokemeter with vehicles having this type of exhaust system. In some cases, exhaust gases can “rebound” off the roadway surface and recirculate through the smokemeter light beam causing erroneously high smoke measurements. This condition can be aggravated if road dust becomes entrained in the recirculating exhaust flow.

In most cases, little can be done to prevent this condition; however, it is recommended that testing personnel attempt to observe whether recirculation is occurring when testing vehicles with downward directed exhaust systems. If recirculation appears to be influencing the smoke measurement, the test results should be considered unreliable (too high) and should be used with caution.

SAE J1667 Issued FEB96

Rationale—Not applicable.

Relationship of SAE Standard to ISO Standard—Not applicable.

Application—This SAE Recommended Practice applies to vehicle exhaust smoke measurements made using the Snap-Acceleration test procedure. Because this is a non-moving vehicle test, this test can be conducted along the roadside, in a truck depot, a vehicle repair facility, or other test facilities. The test is intended to be used on heavy-duty trucks and buses powered by diesel engines. It is designed to be used in conjunction with smokemeters using the light extinction principle of smoke measurement.

This procedure describes how the snap-acceleration test is to be performed. It also gives specifications for the smokemeter and other test instrumentation and describes the algorithm for the measurement and quantification of the exhaust smoke produced during the test. Included are discussions of factors which influence snap-acceleration test results and methods to correct for these conditions. Unless otherwise noted, these correction methodologies are to be considered an integral part of the snap-acceleration test procedure.

Reference Section

SAE J255a—Diesel Engine Smoke Measurement

SAE J1243—Diesel Emission Production Audit Test Procedure

SAE J1349—Engine Power Test Code—Spark Ignition and Compression Ignition—Net Power Rating

SAE J1995—Engine Power Test Code—Spark Ignition and Compression Ignition—Gross Power Rating

ISO CD 11614—Apparatus for the Measurement of the Opacity of the Light Absorption Coefficient of Exhaust Gas from Internal Combustion Engines

Code of Federal Regulations (CFR), Title 40, Part 86, Subpart I—Emission Regulation for New Diesel Heavy-Duty Engines: Smoke Exhaust Test Procedure

Procedures for Demonstrating Correlation Among Smokemeters

Developed by the SAE Heavy-Duty In-Use Emission Standards Committee